

Inspiration for the use of Western Red Cedar

THE CEDAR BOOK

3rd edition



THE CEDAR BOOK

Inspiration for the use of Western Red Cedar

- 6 Anglesey Abbey Visitor Center
- 12 Canada House Installation
- 16 Coffou Cottage
- 21 Crystal Court
- 26 International Center, Deakin University
- 30 EMPAC - Experimental Media and Performing Arts Center
- 35 Hudson-Panos House
- 39 Entry Building, Marin Country Day School
- 43 Orange Memorial Park Recreation Center
- 48 Queens Botanical Garden Visitor & Administration Center
- 53 Richmond Gate Residences
- 59 Whistler Public Library

THE CEDAR BOOK

Editor: Jim Taggart, Architext Communications
Design: Marie Nicole Manseau, Janam Publications Inc.



© 2009 Janam Publications Inc.
With the contribution of Hunter Consulting International Inc.
All Rights Reserved. Published October 2009

Library and Archives Canada Cataloguing in Publication

Taggart, Jim, 1956
The cedar book 2009: inspiration for the use of western red cedar /
Jim Taggart.

ISBN 978 0 9739122 5 8

1. Building, Wooden.
2. Western redcedar.
I. Title.

NA41 I0.T35 2008 694 C2008 905147 5

Cover: *Orange Memorial Park Recreation Center, photo:*
Sharon Risedorph Photography

PRODUCED WITH THE GENEROUS SUPPORT OF



CO SPONSORED BY:



WESTERN RED CEDAR LUMBER ASSOCIATION
(WRCLA) | WWW.REALCEDAR.ORG



WESTERN RED CEDAR EXPORT ASSOCIATION
(WRCEA) | WWW.WRCEA.ORG

Printed in Hong Kong

Western Red Cedar is one of nature's truly remarkable materials. Not only does it have distinctive beauty, natural durability and centuries of proven performance, it is the ultimate sustainable building product. It produces fewer greenhouse gases, generates less water and air pollution, requires less energy to produce than alternatives and comes from a renewable and sustainable resource. Today more than ever before, we must find ways to reduce the pressure on our planet's environment and finite resources. By choosing products with a light carbon footprint and by reducing waste, we can have a real impact on climate change now, and into the future.

Centuries ago, native peoples of the Pacific Northwest recognized the value of using sustainable materials. Western Red Cedar's natural durability, performance characteristics and versatility made it the preferred choice for building ocean-going canoes, post-and-beam houses and lodges. Today, discerning architects and builders around the world enhance their projects with this beautiful and sustainable material. Nature still knows best for, despite all efforts at imitation, no man-made product can match the beauty, performance and longevity of Western Red Cedar.

The 3rd edition of the Cedar Book profiles stunning and award winning architecture from around the world; ranging in scale from the unique Canada House Installation to the remarkable Queens Botanical Garden Visitor and Administration Center, each project illustrates a wonderful integration of the beauty and performance of Western Red Cedar with sustainable architecture.

We hope this book will inspire you to consider Western Red Cedar for your next project. If you already have and are interested in submitting your project for consideration for the next edition of the book, we invite you to send your project details including photo, description and a profile of your firm to the Western Red Cedar Export Association via email to **info@wrcea.org**.

Thank you for your interest in Western Red Cedar.



ANGLESEY ABBEY VISITOR CENTER

SUFFOLK, ENGLAND

Anglesey Abbey House and Gardens were bequeathed to the National Trust in 1966 by the Fairhaven family. The estate comprises some 100 acres (40 hectares) of garden and parkland, and a house whose origins can be traced back to 12th century monastic buildings that were established on the same site.



In 1976 The National Trust commissioned the first permanent visitor center just 300sf in area, providing a small seasonal tea room, shop and information point – a separate washroom block already existed. Eleven additions were built over the next 25 years, as the number of people visiting the garden rose to more than 125,000 annually.

The new building is a 4,300sf (400m²) phased replacement of the old facility, that rationalizes and enhances the existing program, and mediates the transition between the activity of the parking lot and the tranquility of the garden. The structure takes its lead from the original pavilion, conceived within a series of interconnecting pitched steel frames that offer vistas out towards the garden. Between these aisles, the building is linked, by a shallow vaulted reception area that signals both the entrance to the building and the exit to the garden. The aisles, running east to west provide public spaces directly off the lobby.

The first phase, facing south and west and visually connected to the garden, comprises a 180 seat restaurant served by a commercial kitchen, public washrooms and subsidiary spaces. Across

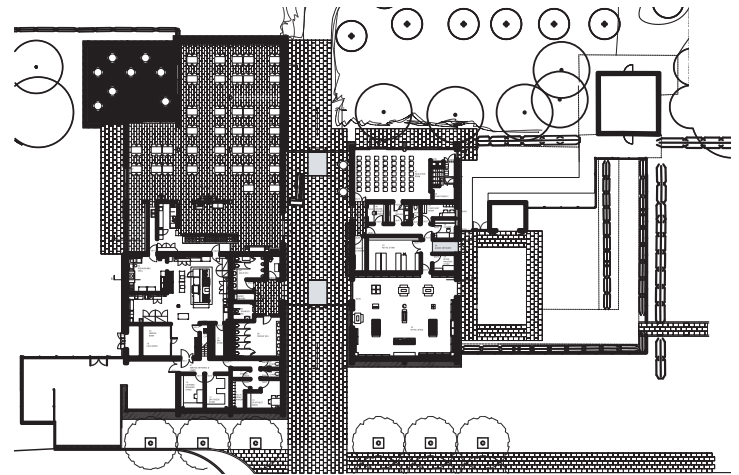

Site plan

A COMBINATION OF WESTERN RED CEDAR PROFILES AND DETAILS CREATE A WARM AND VARIED VISUAL TEXTURE. THE BUILDING PROGRAM IS ORGANIZED BENEATH A SERIES OF VAULTED ROOFS. OVERHANGS AT THE GABLE ENDS FRAME VIEWS TO THE GARDENS.

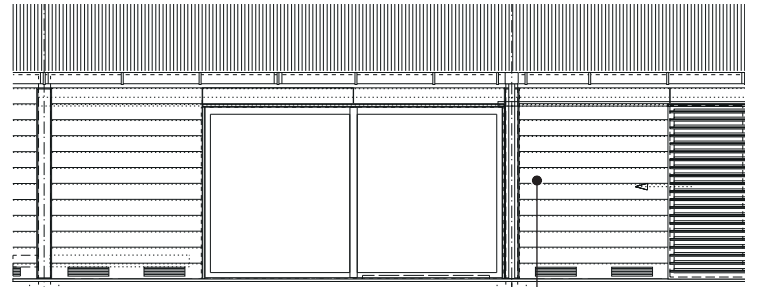

Part side elevation

Western red cedar cladding

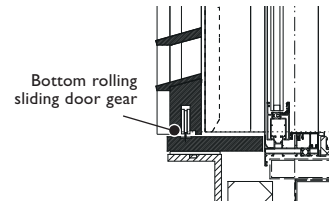
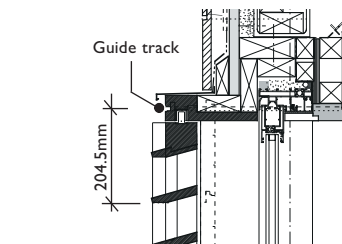

Detail section

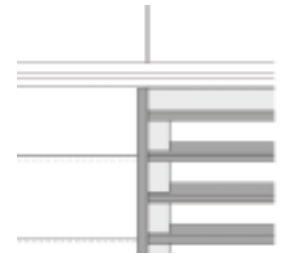

Partial elevation of cedar louvers

Western Red Cedar Specification

Siding - Grade: (British Standard) Class I K 1186 heartwood with limited knots
 Size: finished 1x9in (19 x 225mm)
 Profile: custom milled shi lap
 Fixing: exposed stainless steel screws
 Finish: natural

Slats - Grade: (British Standard) Class I K 1186 heartwood with limited knots
 Size: 1x1-3/4in (25x47mm)
 Profile: custom milled rectangular section
 Fixing: exposed stainless steel screws
 Finish: natural



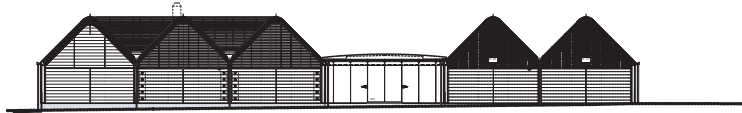

East elevation



North elevation

the lobby in Phase 2 are a multi purpose education room and shop together with “back of house” office spaces.

The structural grid is expressed on the exterior of the building by the introduction of vertical elements in the Western Red Cedar cladding. To reduce the apparent scale of the building, both the east and west elevations step back in plan. Delicate cantilevered aluminum verges and Western Red Cedar brise soleils in the upper sections further soften the gable edges.

A simple palette of modern materials, predominantly mill finished aluminum and untreated Western Red Cedar, will weather with nature, over time, settling into hues of soft silvery greys.

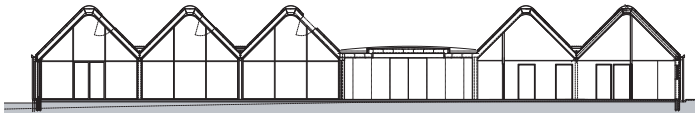

Section A-A

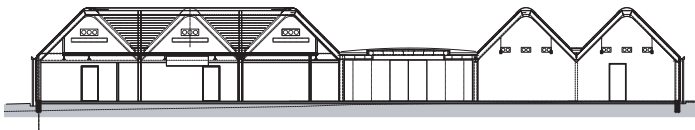

Section B-B



VERTICAL ELEMENTS ON THE BUILDING EXTERIOR EXPRESS THE STRUCTURAL GRID. SUBSEQUENT SUBDIVISIONS OF ALL THE CEDAR ELEMENTS DERIVE FROM A MODULE ASSOCIATED WITH THE MAIN CLADDING BOARD WIDTH.



WESTERN RED CEDAR LOUVERS SHADE THE GLAZING IN THE GABLE ENDS OF THE BUILDING AND FILTER DAYLIGHT INTO THE INTERIOR SPACES.

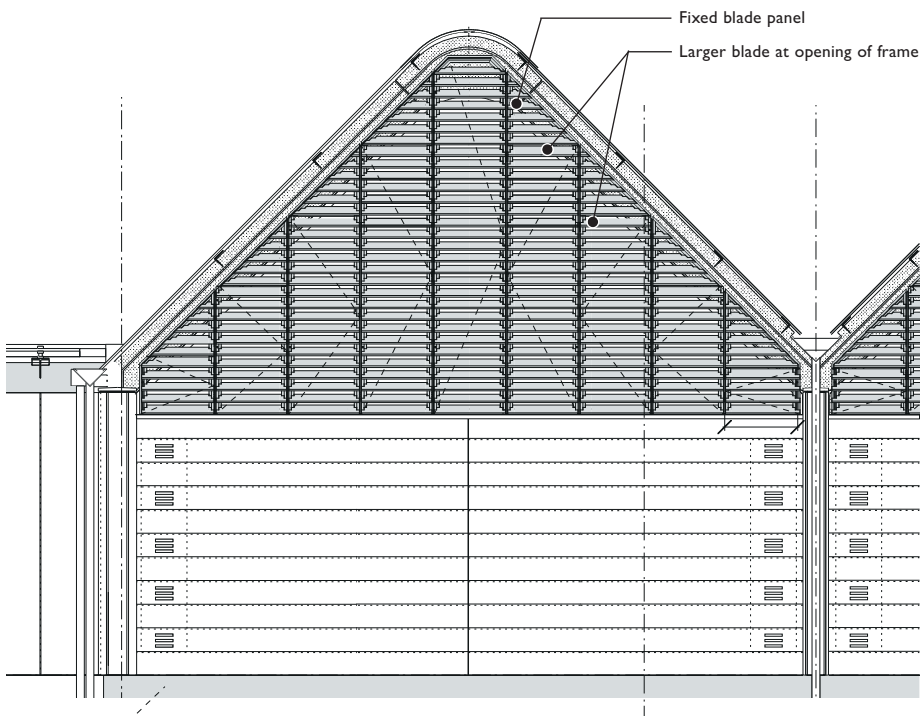

Partial gable elevation

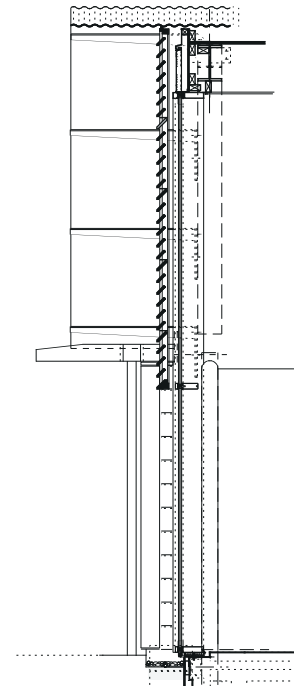

Gable section

CLIENT/PROJECT MANAGER The National trust
ARCHITECT Cowper Griffith Architects
STRUCTURAL ENGINEER Scott Wilson
MECHANICAL/ELECTRICAL Max Fordham LLP
COST CONSULTANT Davis Langdon LLP
GENERAL CONTRACTOR Haymills (Contractors) Limited
CARPENTRY/JOINERY Coulson & Son Ltd
PHOTOGRAPHY Cowper Griffith Architects and Peter Cook



CANADA HOUSE INSTALLATION

LONDON, ENGLAND

As part of Canada's participation in the "Embassies Project" for the 2008 London Festival of Architecture, Canada House was transformed with an undulating wooden wall wrapped around the corner of the historic embassy building.



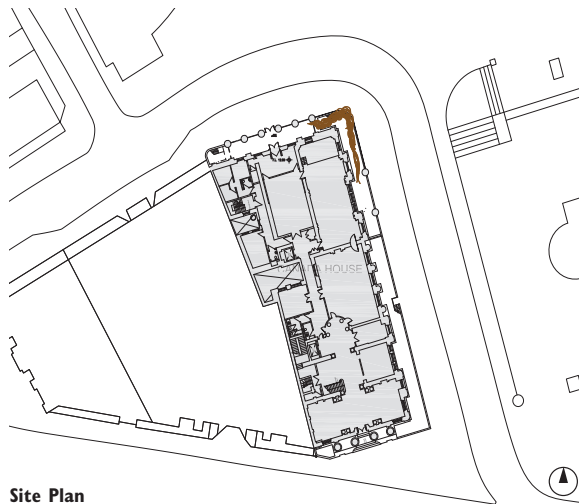

Site Plan

Inspired by the stable, self supporting structure of a bird's nest, this temporary installation consisted of stacked blocks of Western Red Cedar connected by tension cables. Designed using 3 D modeling software, the wall measured 200ft (60m) in length, and rose to a height of 27ft (8.2m). The site at Trafalgar Square afforded a very narrow construction zone between the walls of the heritage structure (which could not be touched), and its perimeter wrought iron railing.

The heart of the wall is simplicity itself: blocks of Western Red Cedar, shaped to fit snugly one next to the other at a range of angles. The Western Red Cedar blocks were milled, edge shaped and pre drilled in British Columbia, Canada. Cables were pre tensioned to make each course of blocks more rigid, then each element was carefully stacked, one on top of the other and pinned together vertically to ensure stability.

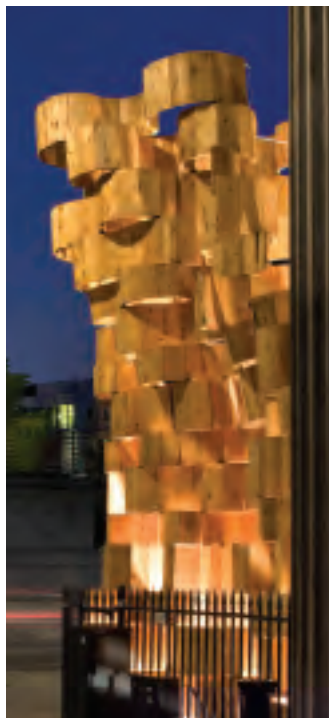

THE UNDULATING PROFILE OF THE WALL IS MADE UP OF SMALL SECTIONS OF WESTERN RED CEDAR HELD TOGETHER HORIZONTALLY BY TENSION CABLES, AND VERTICALLY BY THREADED STEEL RODS.

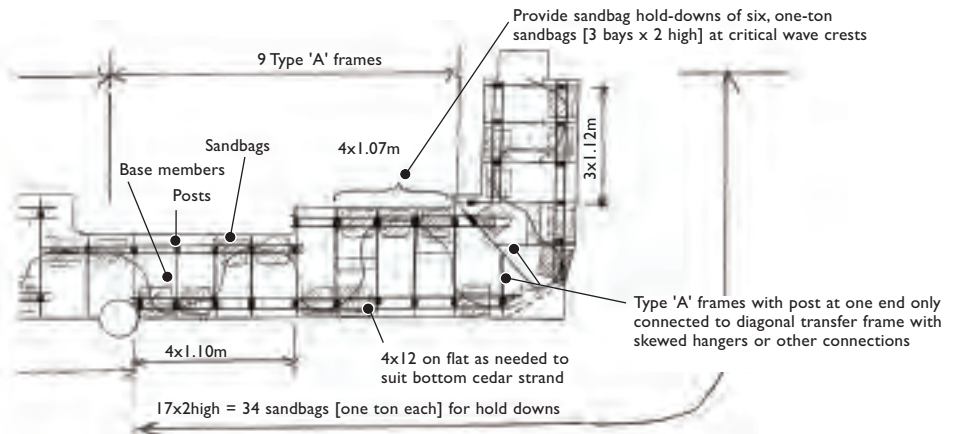

Partial sketch plan

200FT (60M) LONG AND 27FT (8.2M) HIGH, THE TEMPORARY INSTALLATION OCCUPIED THE NARROW ZONE BETWEEN THE HERITAGE STRUCTURE AND THE IRON RAILING THAT DEMARCATES THE EDGE OF THE SITE.



Western Red Cedar Specification

Grade: NLGA Select Knotty (Max 10% Quality Knotty)

Profile: various custom profiles

Size: finished 2x10" (38 x 240mm) in lengths of 10, 14 and 20in) 254, 356 and 508mm)

Fixing: horizontal tension cables and vertical threaded rods

Finish: natural

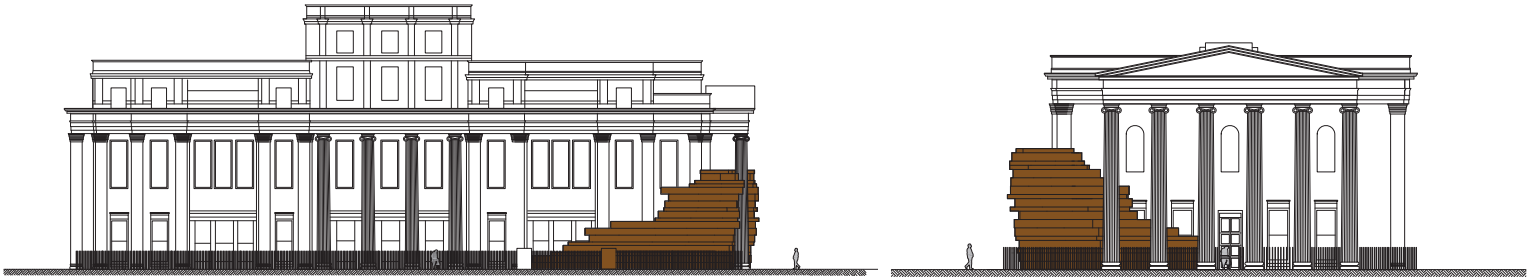

Elevations

Western Red Cedar was selected for its light weight, durability and unique design flexibility, with the many wood blocks easily machined to the right size and fit.

The installation clearly and cleverly demonstrated the versatility of Western Red Cedar, and its suitability for non traditional applications.

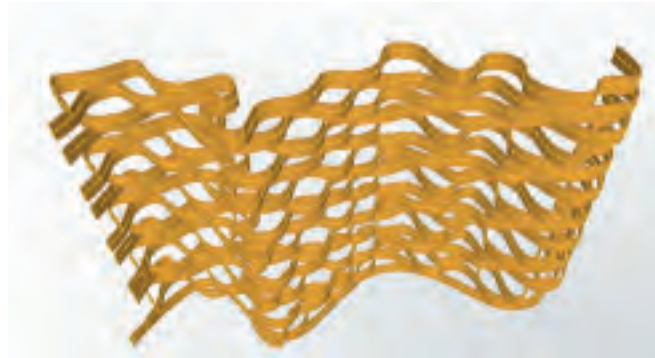

ARCHITECT Bing Thom Architects
 STRUCTURAL ENGINEER Fast + Epp Structural Engineers
 DESIGN/BUILD FABRICATOR StructureCraft Builders Inc
 PHOTOGRAPHY Morely von Sternberg; StructureCraft Builders Inc.

WINNER - 2008 WESTERN RED CEDAR ARCHITECTURAL DESIGN AWARDS (JURY AWARD)

COFFOU COTTAGE

INDIANA USA

For decades the woods and fields of Southwestern Michigan and Northwestern Indiana, with their close proximity to Lake Michigan and short travel distance from the city, have offered Chicago residents weekend reprieves from the pressures of urban life. The owners of this cottage sought a sense of privacy, and preferred the experience of intimate pastoral views to the longer and broader vistas of the lake.



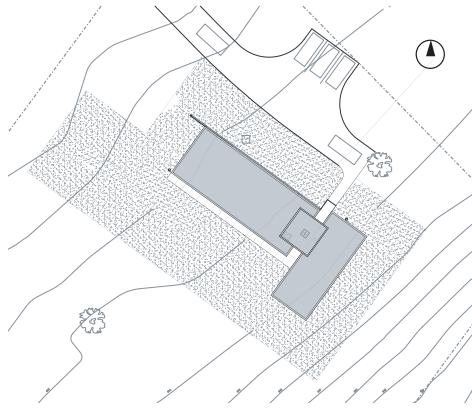

Site plan



They were fortunate to find a piece of land that fit their aspirations, and sought to design a home on it that would meet their modern concept for living.

The 2,800sf cottage has a simple form and structure, enhanced by a horizontal wood rain screen of Western Red Cedar to privatize the entry sequence on the North, and a wall of operable glass on the South. The kitchen, dining, living area, and porch are conceived as a single room, strengthening the views to the meadow and woods to the South. The open plan also maximizes daylight penetration and passive solar gain in the winter months.

Radiant heat in the ground concrete floors runs throughout the three bedroom cottage. The arrangement of rooms and glass exterior walls allows for panoramic views of the surrounding

THE COTTAGE IS CAREFULLY PLANNED TO COMBINE PRIVACY WITH OPENNESS TO VIEWS OVER THE PASTORAL LANDSCAPE. THE WARMTH OF WESTERN RED CEDAR IS CARRIED THROUGH INTO THE INTERIOR OF THE BUILDING.

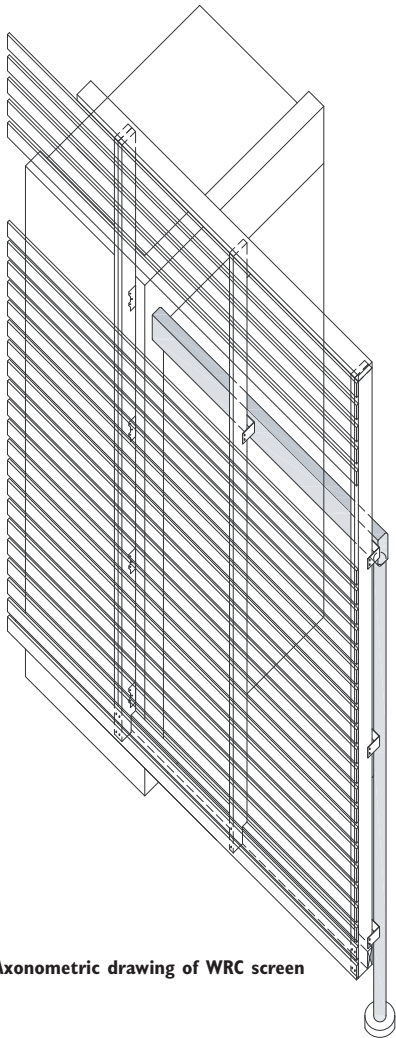

Axonometric drawing of WRC screen

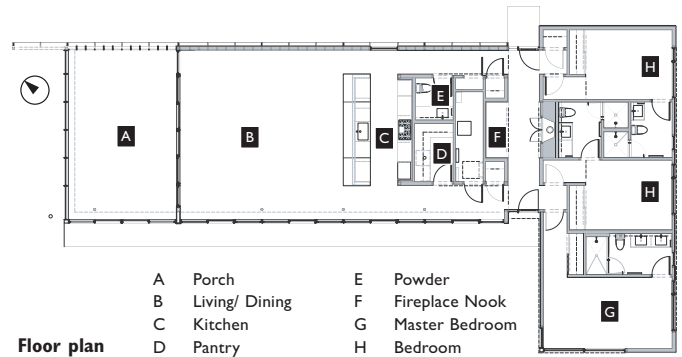

Western Red Cedar Specification

Exterior and Interior Horizontal Siding

Grade: NLGA A & Better Clear (mix grain)

Size: finished 1x6in (19x140mm)

Profile: tongue and groove

Fixing: stainless steel fasteners

Finish: semi-transparent natural tone stain

Exterior Horizontal Screen and Trim Boards

Grade: NLGA A & Better Clear (mix grain)

Size: finished 1x4 (19x89mm)

Fixing: stainless steel fasteners

Finish: semi-transparent natural tone stain

Exterior Vertical Siding and Custom boards

Grade: NLGA A & Better Clear (mix grain)

Size: custom sizes from finished 1x (19mm) material

Fixing: stainless steel fasteners

Finish: semi-transparent natural tone stain

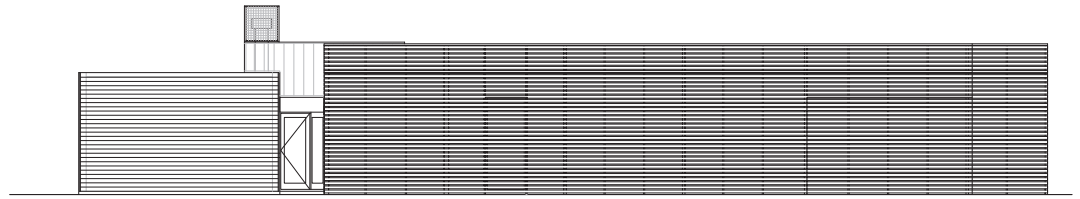

North elevation

environment, while providing the most energy efficient operation. A fireplace is positioned in the front hallway that divides the bedrooms from the living area, and a custom sofa bench set into the wall across from it creates a traditional fireplace inglenook.

Western Red Cedar was used to establish a material warmth and visual interest on the exterior, using a board and batten like pattern for an open screen, to contrast with the solid appearance of the tongue and groove siding used on the house itself. The warmth of material and visual identity is continued in to the interior where the same Western Red Cedar siding is used on interior walls and cabinets, and where the wood screen can be seen from the screened porch and kitchen window.

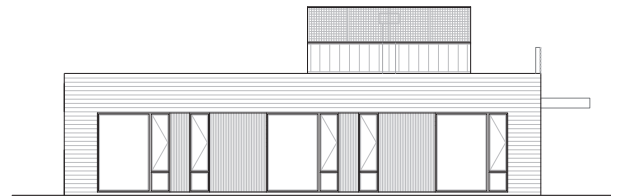

East elevation

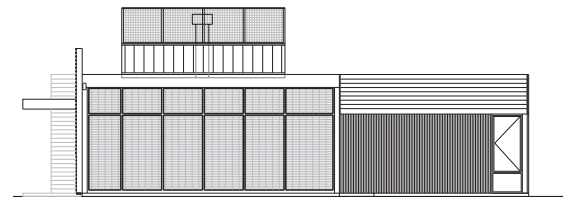

North elevation



A HORIZONTAL SCREEN OF WESTERN RED CEDAR MAINTAINS THE PRIVACY OF THE ENTRY SEQUENCE. OPEN PLAN AND SIMPLE DETAILING ENHANCE THE SENSE OF SPACE.



CLIENT Jim and Sara Coffou
 ARCHITECT Brininstool + Lynch Ltd
 STRUCTURAL ENGINEER C.E. Anderson & Associates
 GENERAL CONTRACTOR Mulcahy Builders
 PHOTOGRAPHY Christopher Barrett, Hedrich Blessing

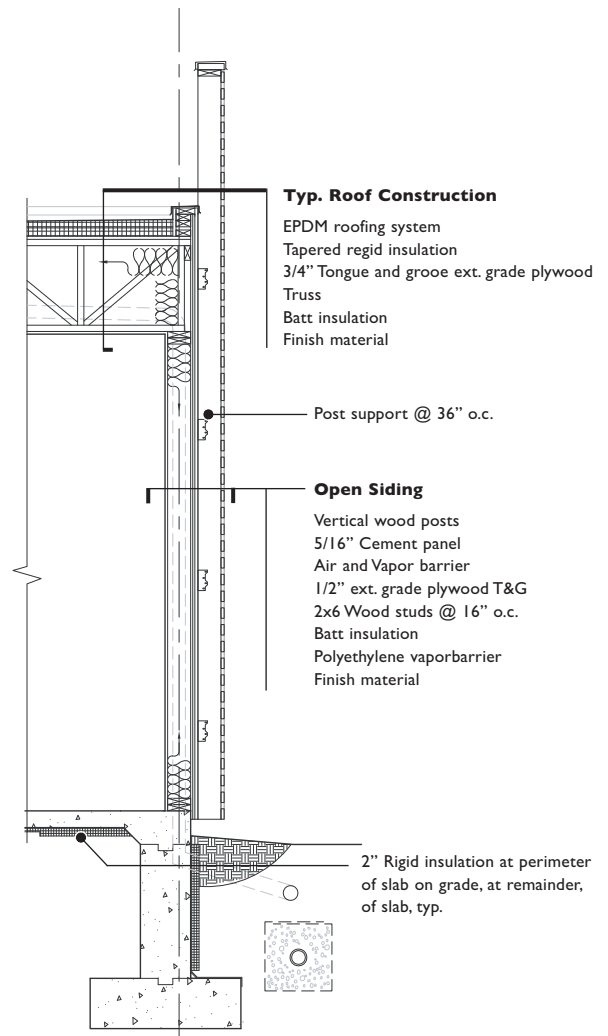

Section through exterior wood screen

ALL THE INTERIOR SPACES HAVE VIEWS TO THE TRANQUIL NATURAL SURROUNDINGS. THE WESTERN RED CEDAR SCREEN MEDIATES BETWEEN BUILDING AND LANDSCAPE.

CRYSTAL COURT

AMSTERDAM, NETHERLANDS

Crystal Court is a medium density, medium rise residential development comprising 36 apartment and detached housing units built over a common underground parking garage. The compact urban site is located between Amsterdam's largest park, the Amsterdamse Bos, and Flevo Park.



Concept sketch

In order to provide as much open space as possible, the residential units have been stacked geometrically, so that a continuous open space is created at ground level on the roof of the parking garage. This area contains landscape and water features that connect it visually to the adjacent parks as well as providing a unique amenity for residents.

A portion of the space between the apartment structures is glazed, creating a communal winter garden that functions as a point of transition between inside and outside. The main entrance lobby is situated here along with other communal



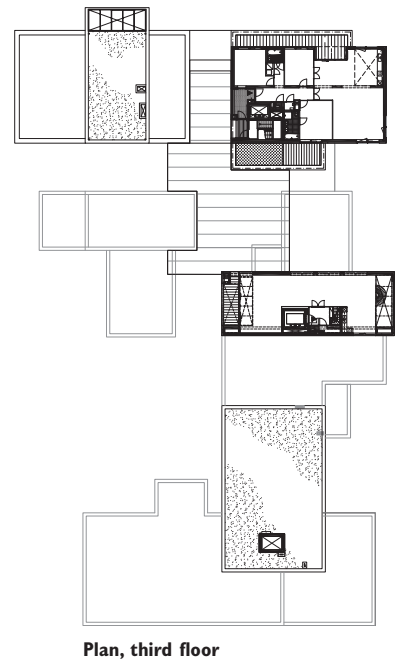
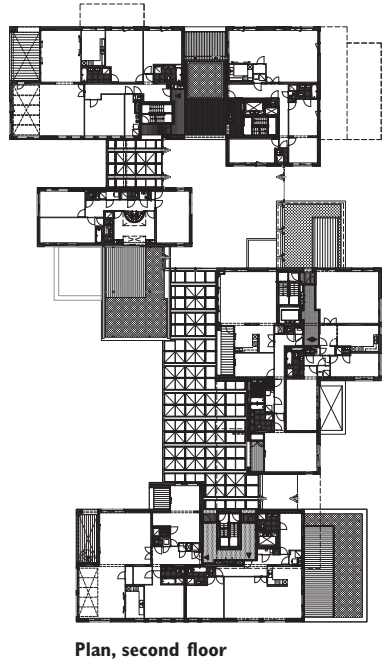
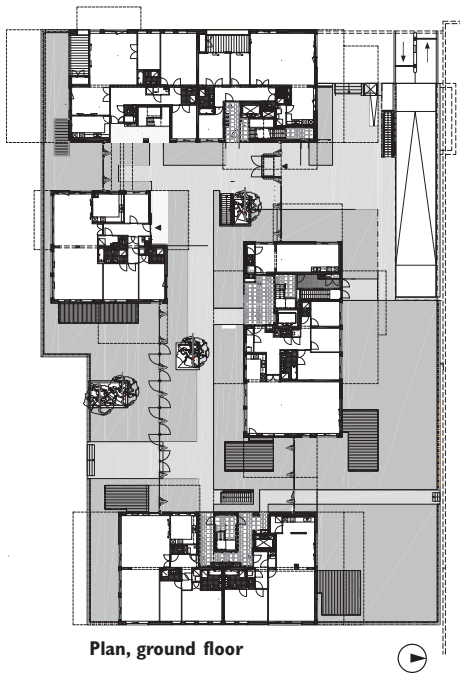

Western Red Cedar Specification

Grade: B (NEN 5471, Netherlands Standards Institute)

Size: finished 1x6in (19x140mm)

Profile: rectangular

Fixing: stainless steel nails

Finish: fire retardant pressure treated, white stain

THE 36 RESIDENTIAL UNITS ARE STACKED GEOMETRICALLY TO MAXIMIZE OPEN SPACE AT GROUND LEVEL. WATER FEATURES, PLANTING AND THE VERTICAL WESTERN RED CEDAR CLADDING CONNECT THE COMPLEX VISUALLY TO THE ADJACENT PARKS. THE 3-DIMENSIONAL GEOMETRY OF THE COMPLEX ENABLES ALL UNITS TO ENJOY PRIVACY, AND YET RECEIVE AMPLE DAYLIGHT. THE TWO BUILDINGS THAT COMPRISE THE COMPLEX ARE CONNECTED BY A CENTRAL GLAZED ATRIUM.



facilities, including a Laundromat and workspaces for the care taker. A central garden with reflecting pools creates a central focus for this space.

The three dimensional geometry of the complex enables all 36 dwellings to enjoy privacy, yet benefit from optimal daylight penetration and views. Most units have balconies facing both the exterior and the winter garden. One of the most important characteristics of this design is the way in which the 'unbuilt' space is entwined with a building, creating a sense of openness rare in a project of this density. This intricate puzzle like design results in a complex interplay between the stacked sculptures, the open space between the buildings and their green surroundings.

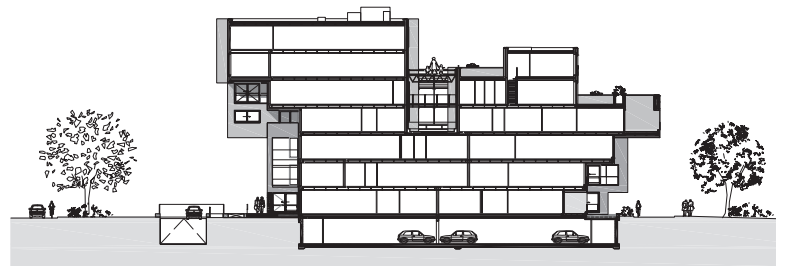

Section





CLIENT Hillen & Roosen Projectontwikkeling bv
 ARCHITECT Tangram Architekten
 STRUCTURAL ENGINEER Van Rossum Raadgevende Ingenieurs
 GENERAL CONTRACTOR Hillen & Roosen Projectontwikkeling bv
 PHOTOGRAPHY John Lewis Marshall

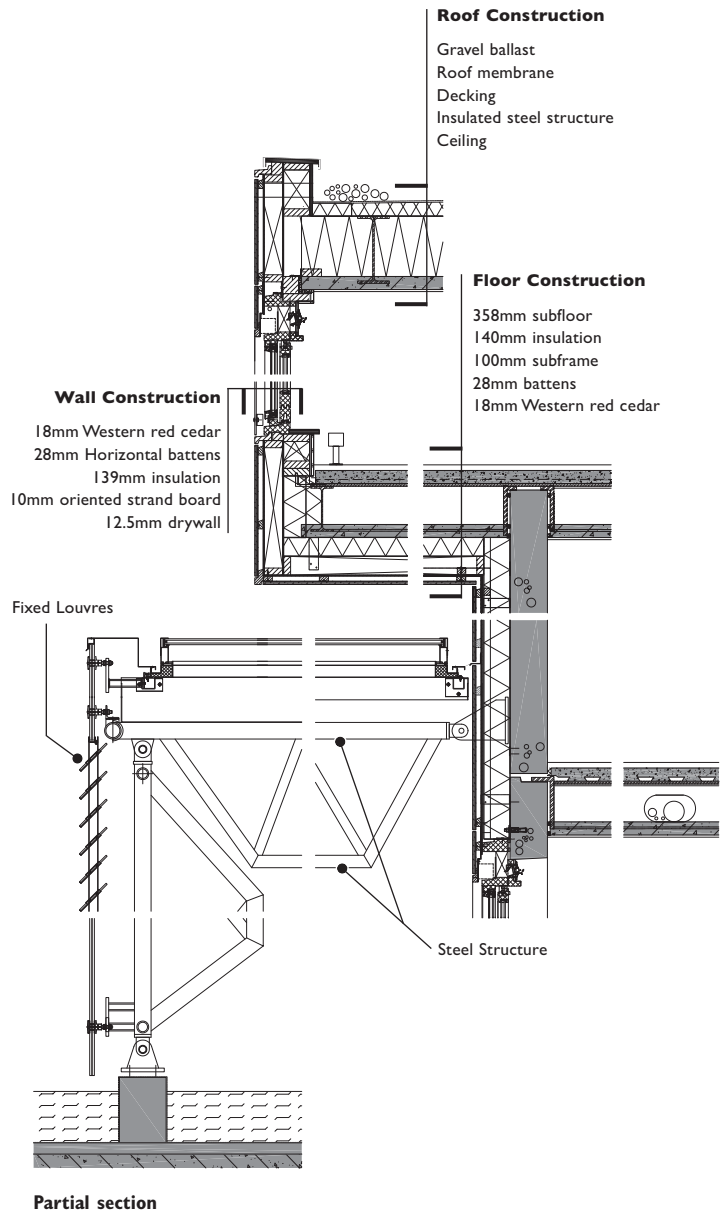



Structural considerations required that the finish applied to the facade be light in weight; Western Red Cedar was chosen as a complement to the park like setting of the project. The wood is whitewashed to blend in with the neighbouring light coloured brick apartment buildings and to ensure a uniform finish between interior and exterior applications at the winter garden. The wood was also treated to comply with fire regulations.

THE LANDSCAPED ATRIUM GIVES ACCESS TO BOTH BUILDINGS AND TO COMMON FACILITIES AS WELL AS PROVIDING A VARIETY OF OPPORTUNITIES FOR INFORMAL MEETINGS BETWEEN RESIDENTS. THE GLASS SKYLIGHT FOLLOWS THE COMPLEX GEOMETRY OF THE RESIDENTIAL UNITS.



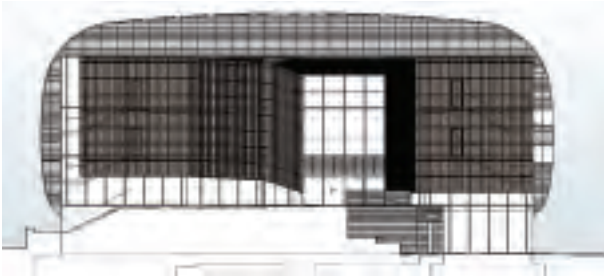

West elevation, cedar shown in dark



Longitudinal section



INTERNATIONAL CENTER, DEAKIN UNIVERSITY

VICTORIA, AUSTRALIA

This project represents the first phase in the development of the western campus of Deakin University in Victoria, Australia. The project includes approximately 190,000sf (17,500m²) of teaching facilities, cafes, foyers, reception areas, shared communal atrium lounges and light courts.

The university wanted a building that would act as a landmark and establish a new benchmark for sustainable design, while also respecting and responding to its context.

The design incorporates internal light courts to maximize daylight to the interiors. The east west orientation and the use of sun shading will ensure minimum heat loading in summer and maximum in winter. The buildings are naturally ventilated with air that is tempered by passing it through the concrete floor structure.

Fixed Panelised Western Red Cedar louvres screen and shelter the curved east and west facades giving the building an iconic yet non institutional appearance. These panels also create a double skin facade system that screens the buildings from additional heat load. The gap between the timber screens and inner glazed skin behind the louvres is used for passive venting reducing the thermal load on the building without additional running costs.

Western Red Cedar was also chosen for the ease and economy with which it could be fabricated into modular panels off site, with the attendant benefits of time saving, quality assurance and simplicity of site installation.



Site plan



WESTERN RED CEDAR SCREENS CONTRIBUTE TO THE ICONIC ARCHITECTURE OF THE NEW INTERNATIONAL CENTER. THE CEDAR ELEMENTS WERE PRECUT, PREDRILLED AND FABRICATED INTO PANELS PRIOR TO INSTALLATION.

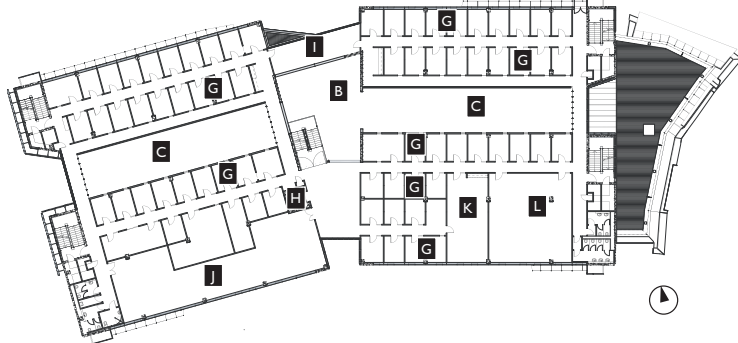
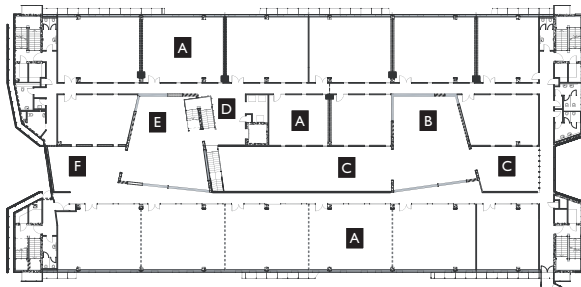

- | | | |
|---------------|-----------------------|-----------------|
| A Classroom | E Student common room | I Balcony |
| B Atrium | F Foyer | J Future growth |
| C Light court | G Office | K Meeting room |
| D Lobby | H Elevator | L Open plan |

Plan, third floor

ON THE EAST AND WEST ELEVATIONS THE WESTERN RED CEDAR SCREENS ARE HELD OFF THE GLAZED FACADES, PROTECTING THEM FROM SOLAR RADIATION AND CREATING A VENTILATION SPACE BETWEEN SCREEN AND BUILDING.

Western Red Cedar Specification

- Grade: D clear
- Profile: rectangular boards with pre-drilled holes top and bottom
- Size: surfaced 2x6in (42 x 145mm)
- Fixing: attached to steel sub frames using countersunk stainless steel screws
- Finish: natural

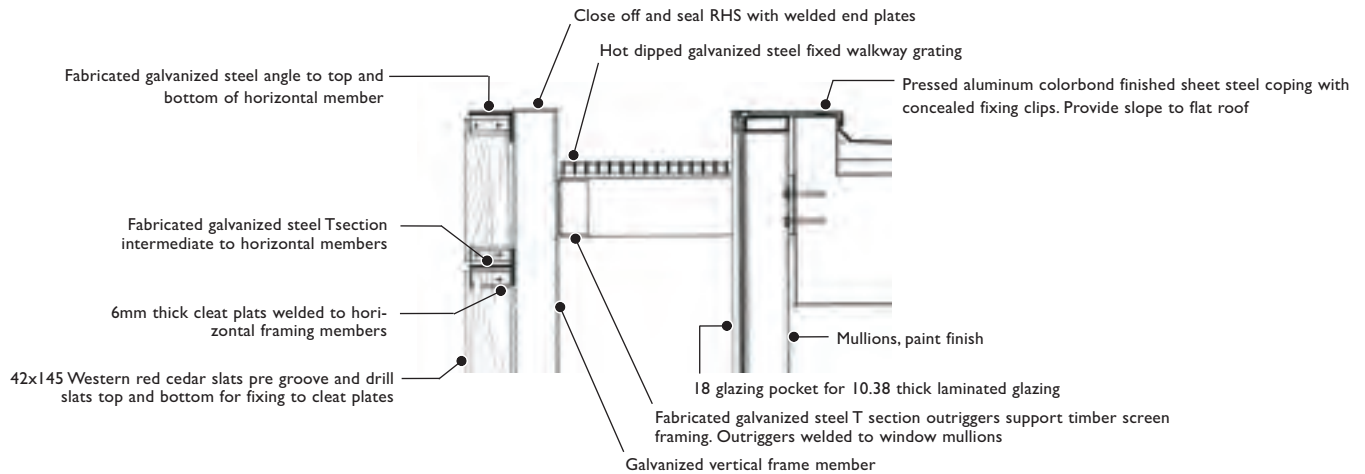

Detail section, sunshade screen and glazing

Cleat plates welded to horizontal framing members, pre-slotted timber slats slide on fixing cleats and bolt in position

45x145 Western red cedar slats pre groove and drill slats top and bottom for fixing to cleat plates

Intermediate horizontal sections welded to vertical frame members

150x150x4 galvanized RHS vertical frame members

Fabricated galvanized steel T section outriggers support timber sunshade screen framing

Hot dipped galvanized steel walkway grating fixed to T section outriggers

150x50x4 mullions paint finish

Edge of concrete slab

Detail plan, sunshade screen, external walkway and windows



CLIENT Deakin University Property Services Division
ARCHITECT / INTERIOR DESIGNER H2o architects
STRUCTURAL ENGINEER Deakin University Project design & Construction Management (PDCM)
MECHANICAL/ELECTRICAL ENGINEERS Waterman AHW Consulting Engineers (Vic)
COST CONSULTANT Wilde & Woollard
CONSTRUCTION MANAGER Deakin University Project Design & Construction Management (PDCM) and Wycombe Constructions
PHOTOGRAPHER Trevor Mein



Western Red Cedar Specification

Grade: NLGA A & Better Clear (vertical grain)
Profile: custom rounded edge, reinforced tongue and groove
Size: face 6in (152mm); tongue 5/16" (8mm); thickness 16mm
Fixing: blind fastening in groove using stainless steel staples into continuous battens
Finish: synthetic clear lacquer

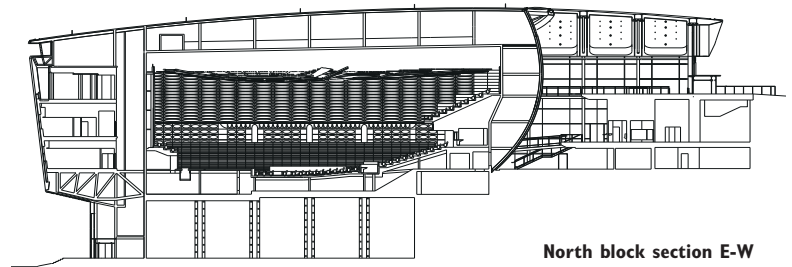

EMPAC - EXPERIMENTAL MEDIA AND PERFORMING ARTS CENTER

TROY, NEW YORK, USA



Located at Rensselaer Polytechnic Institute in Troy, NY, EMPAC opened in October 2008. The building is a laboratory for both performing arts and science and provides state-of-the-art immersive environments for the senses of seeing and hearing including a concert hall, a theater, three performance studios and record-

The concert hall is the centerpiece of the building and is contained inside an enormous double curved wooden "hull", clad entirely in Western Red Cedar. The material for the 15,000 linear feet (4,570m) of tongue and groove planks was sourced from sustainably managed forests in British Columbia.

The material was shipped to Pennsylvania, where it was resawn to the proper thickness and air dried over a 9 month period. It was then molded to the correct profile to permit the tongue and groove to be engaged over a curved surface, and to permit extra movement as the 65ft (20m) high wall had 120 pieces stacked diagonally, and the need to accommodate up to 8in (200mm) of thermal and moisture movement. To further accommodate stresses in the wall, the joint design incorporates a crush bead.

THE CENTERPIECE OF THE BUILDING IS A CONCERT HALL ENCLOSED BY A SCULPTURAL DOUBLE-CURVED HULL CLAD ENTIRELY IN TONGUE AND GROOVE WESTERN RED CEDAR BOARDS.

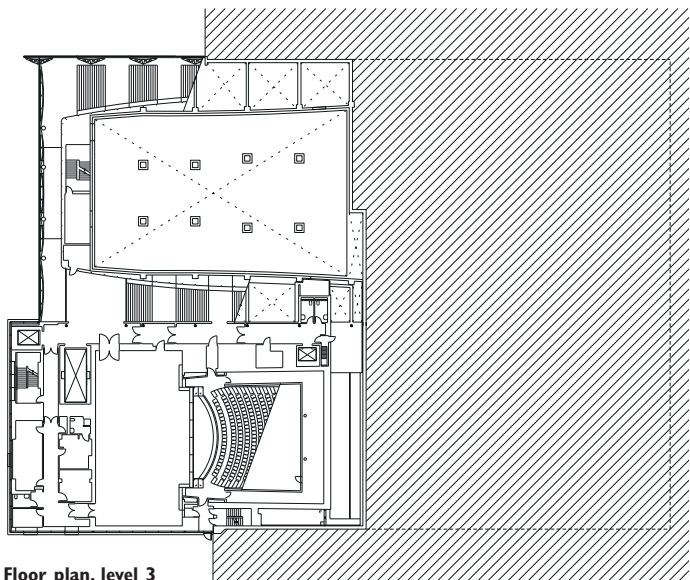

Floor plan, level 3

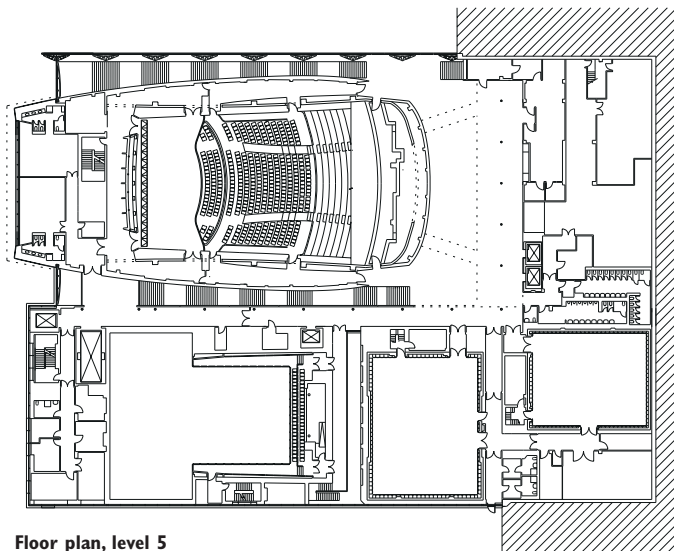

Floor plan, level 5

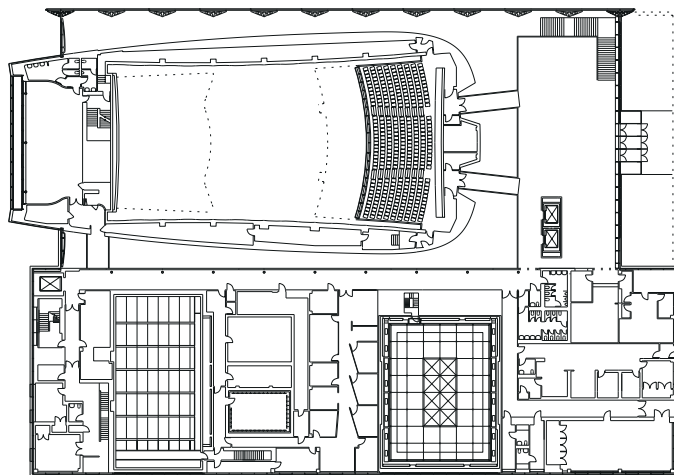

Floor plan, level 7



THE SCULPTURAL FORM OF THE CONCERT HALL IS VISIBLE WITHIN THE GLAZED RECTANGULAR SHELL OF THE BUILDING. THE WESTERN RED CEDAR WAS SOURCED FROM SUSTAINABLY MANAGED FORESTS IN BRITISH COLUMBIA.

Western Red Cedar was selected for its superior technical performance characteristics in addition to its beautiful aesthetic qualities. The wood hull for EMPAC was subjected to a stringent series of flame spread tests and the Western Red Cedar was judged to inherently conform to the Class B rating required.

The design team collaborated extensively on the project's details and construction methodology with the millwork contractor, who at the outset of the project constructed a full scale mock up of a section of the hull to allow the team to develop the architectural details and most appropriate mechanical fastening techniques.



WESTERN RED CEDAR BOARDS WERE PRE-FORMED TO BETTER FIT THE DOUBLE CURVED SURFACE. THE SPECIALLY DESIGNED JOINTS HAVE A CUSTOM PROFILE AND A CRUSH BEAD TO MAINTAIN THE INTEGRITY OF THE SURFACE WHILE ACCOMMODATING THE ANTICIPATED THERMAL AND MOISTURE MOVEMENT.

DESIGN ARCHITECT Grimshaw
 ARCHITECT OF RECORD Davis Brody Bond Aedas
 STRUCTURAL ENGINEER Buro Happold
 CONSTRUCTION MANAGER Tishman Construction
 ACOUSTICIAN Kirkegaard Associates
 THEATRE CONSULTANT Fisher Dachs Associates
 WESTERN RED CEDAR SUBCONTRACTOR Architectural Woodwork Industries
 WESTERN RED CEDAR FINISHING S & S Molding Company

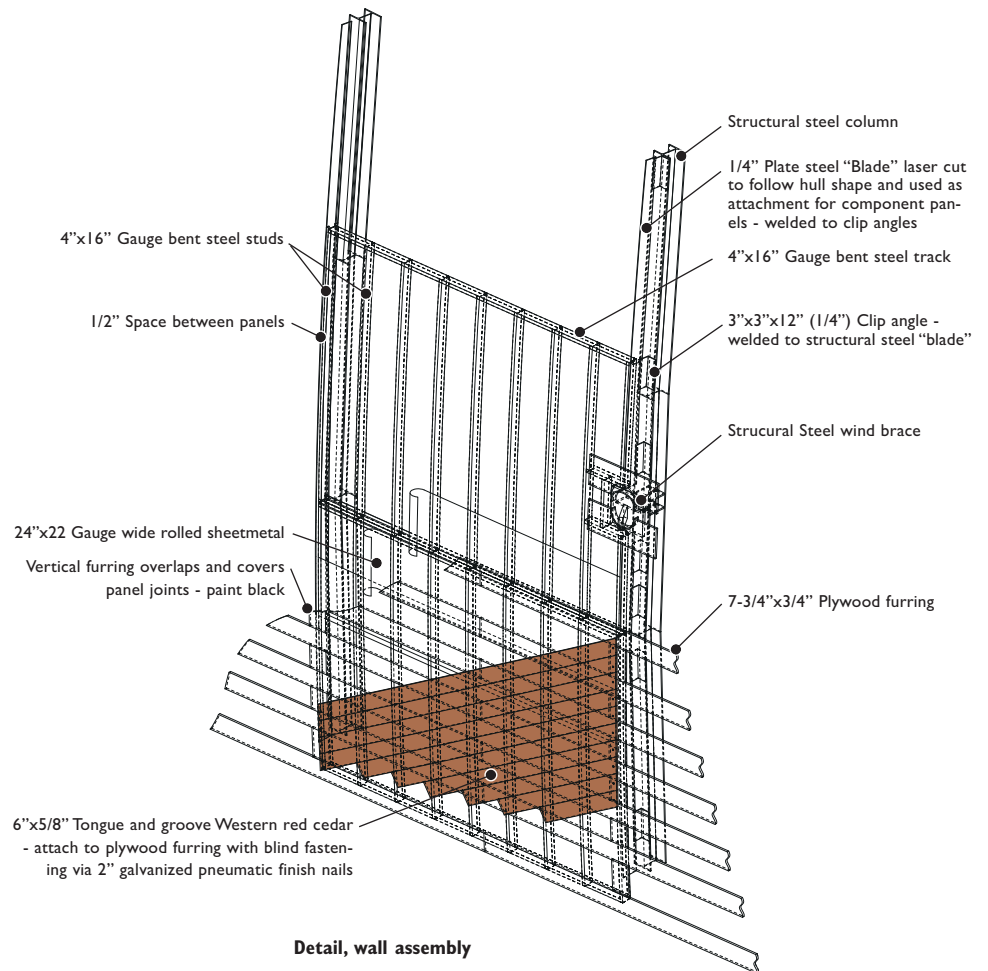

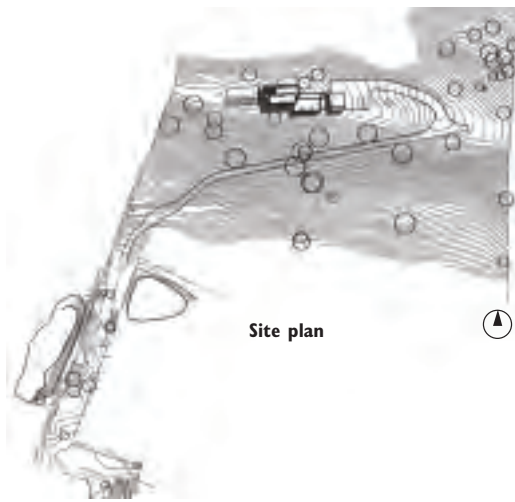

Site plan

WINNER - 2008 WESTERN RED CEDAR ARCHITECTURAL
DESIGN AWARDS (CITATION AWARD)

HUDSON-PANOS HOUSE

HEALDSBURG, CALIFORNIA USA

This 2,900sf (270m²) vacation home provides the San Francisco-based clients with a restful family getaway in the heart of wine country.



Western Red Cedar Specification

Interior and exterior

Grade: premium grade, clear Western Red Cedar

Profile: tongue and groove square edge (interior) and V-groove (exterior)

Size: finished 1x4in (19x89mm)

Fastening method: blind nailing

Finish: 2 coats translucent high solids alkyd finish, natural light colour (exterior), resistant UV (interior)

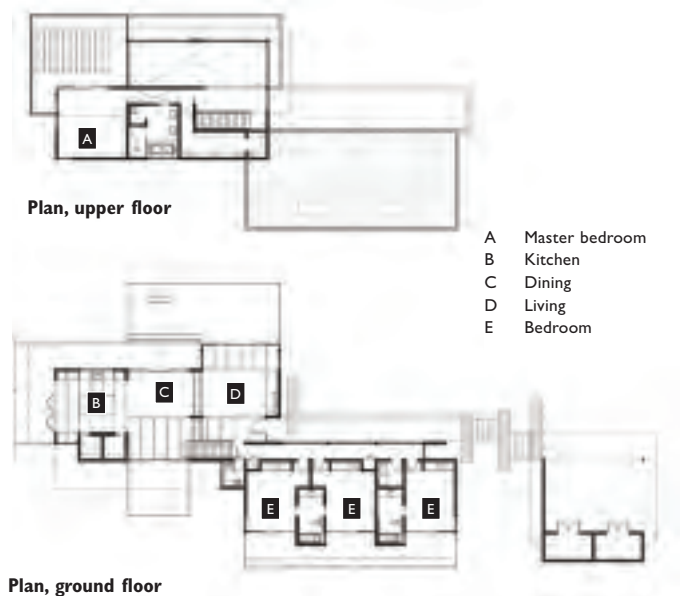

THE HOUSE IS SITUATED ON A LONG, SLENDER KNOLL BORDERED BY DOUGLAS FIR, MADRONE AND MATURE OAK TREES, WITH VIEWS OVER THE DRY CREEK VALLEY TO THE NORTH.

EXPOSED GLULAM BEAMS AND OTHER WOOD ELEMENTS PROVIDE A WARM AND TEXTURED COUNTERPOINT TO THE CLEAN LINES AND LIGHT COLOURS OF THE OTHER INTERIOR FINISHES. EXTERIOR SOFFITS ARE FINISHED IN WESTERN RED CEDAR EXTENDING THE PALETTE OUT INTO THE LANDSCAPE.



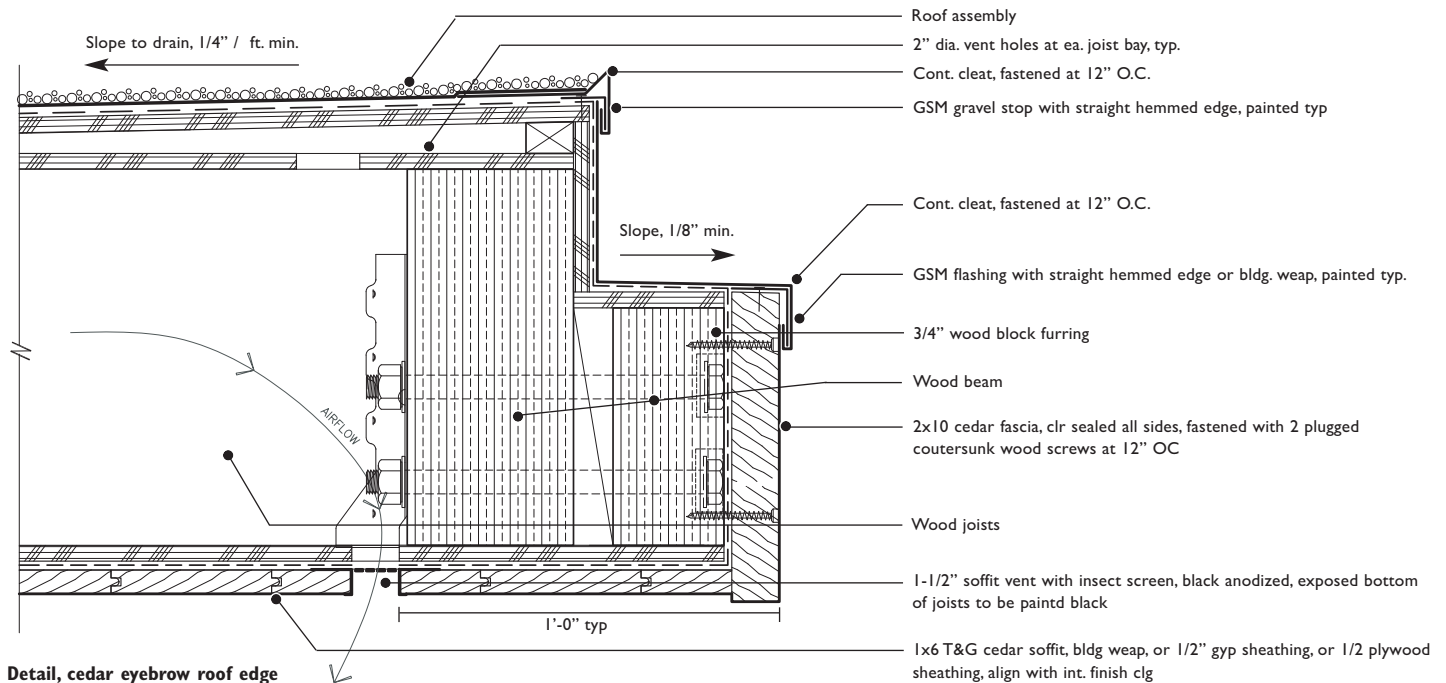

The house is set on a long, slender knoll on the nine acre (3.6 hectare) hillside property. The knoll, running east west, is bordered by Douglas fir, Madrone and mature Oak trees on the east, south and west sides, and features unobstructed views of the Dry Creek Valley to the north.

The home consists of two parallel wings that are slightly offset to create a linear courtyard. The east wing contains the children's and guest bedrooms while the west wing contains public spaces on the lower level and the master bedroom suite on the upper level. A large, two storey volume with clerestory glazing creates an exciting vertical counterpoint to the mostly horizontal design, and bathes the interior with natural light.



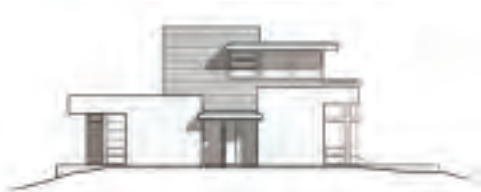

East elevation

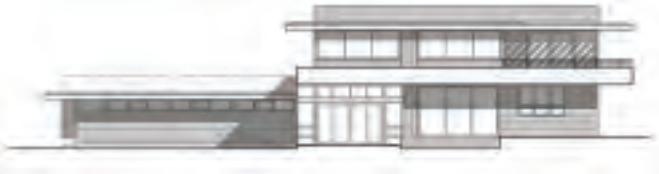

North elevation

The exterior palette comprises a mix of durable, complementary materials, including gray integral coloured stucco, silver painted aluminum clad windows, and clear finished 1x4 Western Red Cedar boards. The Cedar both enhances the warmth of the design and reflects the home's environment.

As the home's feature element, Western Red Cedar is further applied to the soffits, ceilings, overhangs and trellises. When combined with the exposed glulam beams, these natural wood elements help to extend the views outward and blur the boundary between interior and exterior spaces.



South elevation



West elevation

THE HOUSE IS DIVIDED INTO TWO PARALLEL WINGS, SLIGHTLY OFFSET FROM ONE ANOTHER TO CREATE A LINEAR COURTYARD,



CLIENT Leigh Hudson and Chris Panos
ARCHITECT Swatt Architects
STRUCTURAL ENGINEER Yu Strandberg Engineering
GENERAL CONTRACTOR Kasten Builders
WRC SUPPLIER Golden State Lumber
PHOTOGRAPHY Russell Abraham Photography

WINNER - 2008 WESTERN RED CEDAR ARCHITECTURAL
DESIGN AWARDS (CITATION AWARD)

ENTRY BUILDING, MARIN COUNTRY DAY SCHOOL

CORTE MADERA, CALIFORNIA, USA

Though it has a modest footprint of only 9ft x 36ft (2.7m x 11m), the school's aspirations for its new entry building were anything but small.

The building had only two basic programmatic needs: a shelter for children waiting for their parents and storage for athletic equipment; however the understanding was that it had a broader purpose that made it an essential component of the master plan.

It was intended to serve both physically and symbolically as the point of arrival for the school located across the road from the parking lot and drop off. The building's simplicity lends it an iconic yet understated street presence, referencing with respect the large campus of wood buildings on the other side.

Wood framing and siding seemed to be the natural choice for this building. The 1x6 horizontal siding boards with custom milled v grooves were left over from another project recently completed by the architects.

The boards were finished with a semi transparent stain that allowed the natural colour variation to enliven the monolithic surfaces. Face nailing was avoided as it would have imposed an unwanted order on the facade. Instead, the siding is blind nailed

TO MAINTAIN THE CLEAN LINES OF THE PRISMATIC FORM, THE WESTERN RED CEDAR CLADDING HAS BEEN DETAILED TO COVER THE USUAL METAL PARAPET FLASHING. THE ONLY VISIBLE FASTENERS ARE EXPOSED ALLEN HEAD SCREWS AT THE MITRED CORNERS



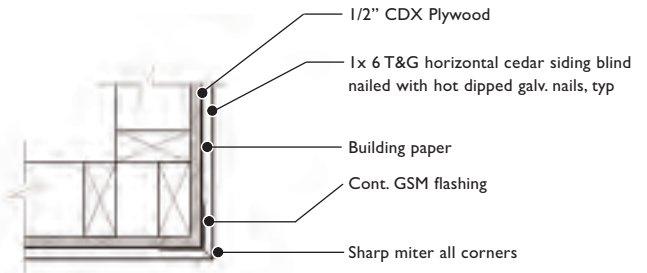
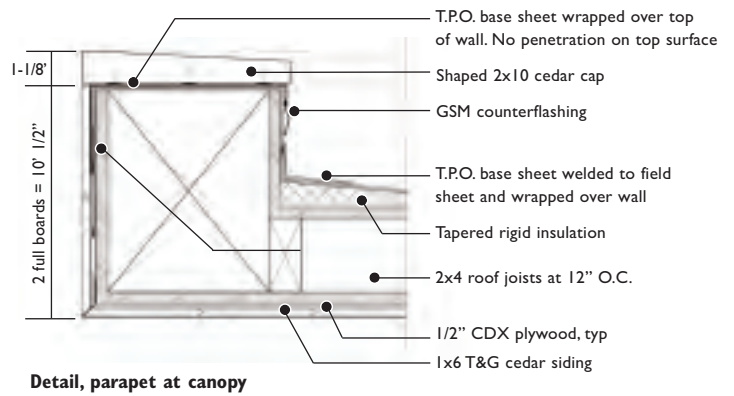
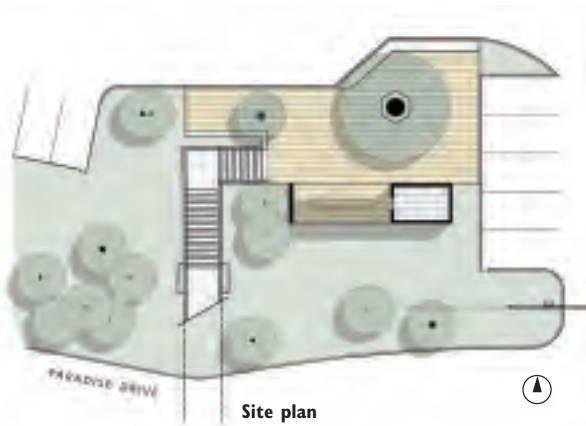

CONCEIVED AS A MONOLITHIC RECTANGULAR VOLUME INTO WHICH OPENINGS HAVE BEEN INCISED, THE ENTRY BUILDING HAS A STREET PRESENCE THAT BELIES ITS MODEST SCALE. THE CLADDING IS FASTENED WITH CONCEALED NAILS SO AS NOT TO BREAK THE CONTINUITY OF THE EXTERIOR SURFACES.

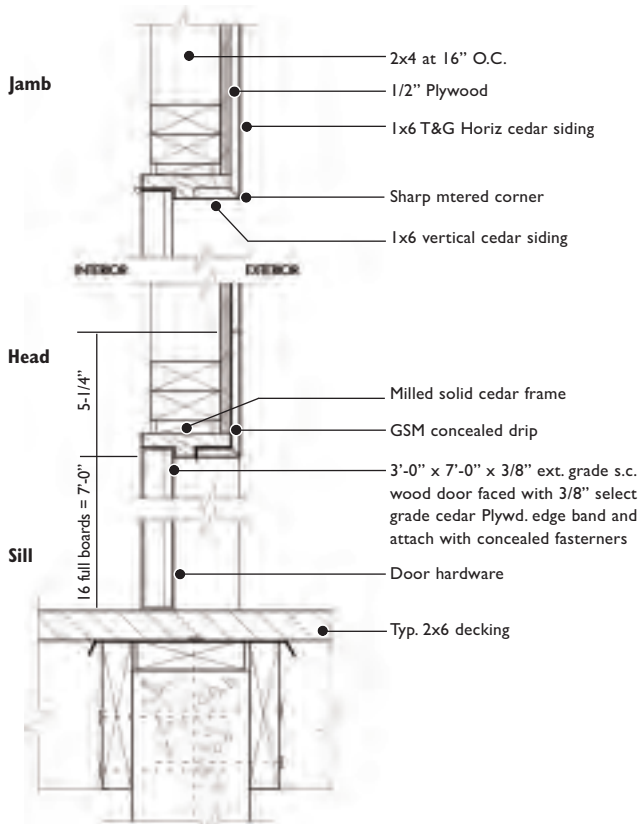

Door details

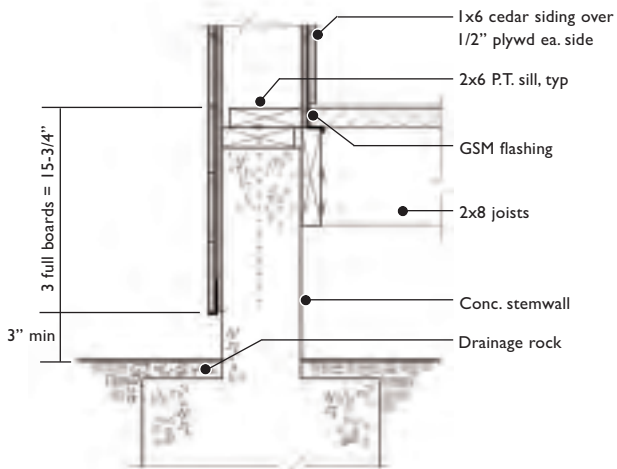

Sill details



Western Red Cedar Specification

Grade: NLGA A & Better Clear

Profile: custom V-groove

Size: surfaced 1x6in (19x140mm)

Fixing: concealed nails, Allen head screws at mitred corners

Finish: semi-transparent stain

THE WESTERN RED CEDAR CLADDING IS LAID WITH STAGGERED JOINTS AND FINISHED WITH SEMI-TRANSPARENT STAIN THAT PERMITS THE NATURAL VARIATIONS IN COLOUR AND GRAIN TO SHOW THROUGH.

CLIENT Marin Country Day School
ARCHITECT Mark Cavagnero Associates
STRUCTURAL ENGINEER Jon Brody Engineers
LANDSCAPE ARCHITECT Michael Painter Associates
GENERAL CONTRACTOR Kelly Pacific
PROJECT/CONSTRUCTION MANAGER ATC Partners
PHOTOGRAPHY Tim Griffith Photography

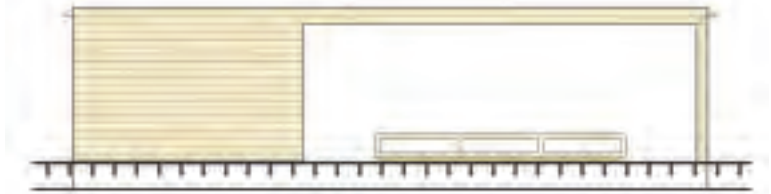

Elevation

in its entirety with staggered vertical joints laid in the field, further enhancing the natural form of the wood. Allen head screws at the corners only secure the mitre cut boards.

It was imperative to detail the roof verge to conceal the traditional sheet metal coping with a cedar siding board, allowing the building to meet the sky in a more sculptural and poetic manner.



WINNER - 2008 WESTERN RED CEDAR ARCHITECTURAL
DESIGN AWARDS (JURY AWARD)

ORANGE MEMORIAL PARK RECREATION CENTER

SAN FRANCISCO, CALIFORNIA, USA

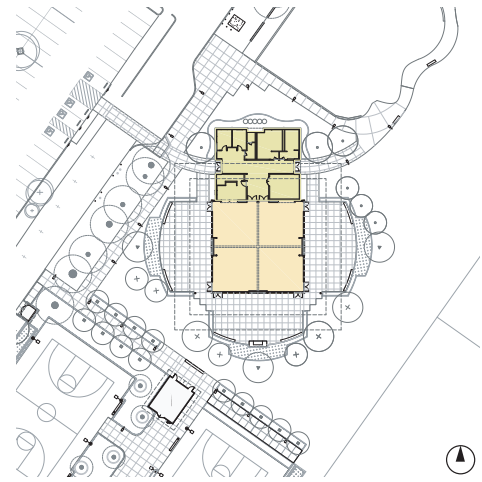

Site plan

Orange Memorial Park is the most important public recreation venue for the citizens of South San Francisco.

The new 6,400sf (600m²) recreation building is encircled by soccer, picnic, basketball and other outdoor amenities. The focal program element is an airy, light filled, multipurpose activity room which has three sides of windows and opens onto surrounding patios, creating a seamless connection between indoors and outdoors.

The recreation building is conceived as a pavilion in a park, made up of two simple and distinct rectangular volumes: one large, light and mostly transparent, housing the activity room, with large areas of glass juxtaposed with Western Red and Yellow Cedar; and another mass that is by contrast a smaller, nearly solid box of basalt stone. The horizontality of the building is accentuated by the roof of the larger volume whose

THE NEW PAVILION IS RENDERED IN A PALETTE OF DURABLE NATURAL MATERIALS INCLUDING WESTERN RED CEDAR, YELLOW CEDAR AND BASALT STONE.

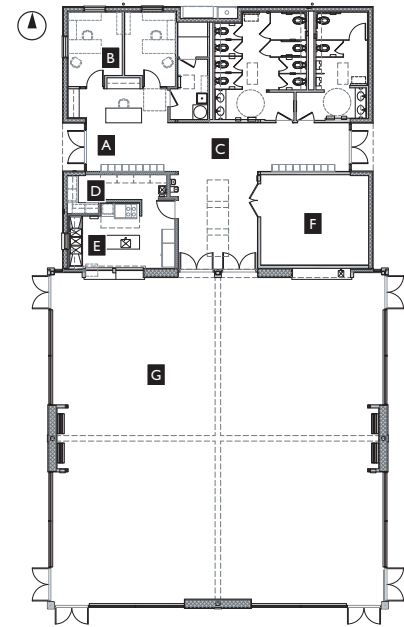

- A Office
- B Reception
- C Hallway
- D Pantry
- E Storage
- F Kitchen
- G Activity pavilion

Floor plan

paired glulam trusses cantilever beyond the enclosed footprint to provide covered outdoor patio areas, with the truss top chord and sunshade framing extending yet farther beyond.

The design team wanted the green features of the project to lend strong architectural expression to the building. Most important in this regard are the siting of the project for optimal solar orientation, the deep overhangs and sunshades, and the abundant sun protected fenestration that provided natural day lighting and views.

THE CLEAN LINES AND SIMPLE GEOMETRY OF THE PAVILION MAKE IT A NATURAL FOCAL POINT FOR THE SURROUNDING PARK. THE LARGER OF THE TWO RECTANGULAR VOLUMES IS RENDERED AS A TRANSPARENT GLASS BOX; THE SMALLER AN ALMOST SOLID MASS OF BASALT STONE.

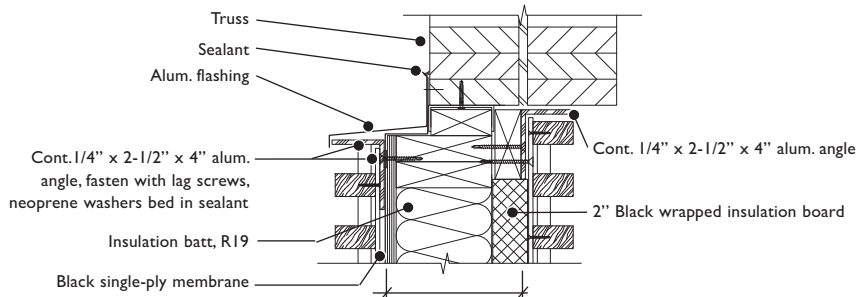

Detail A: Top of wood grate

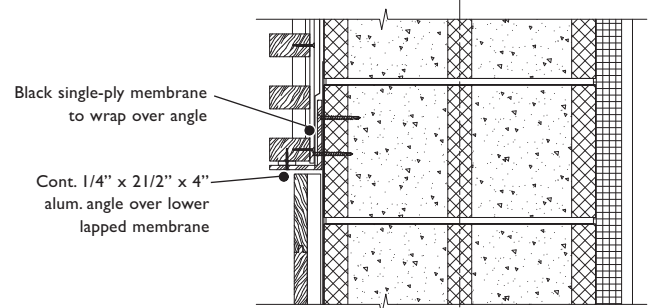

T & G WD. siding / WD. grate transition

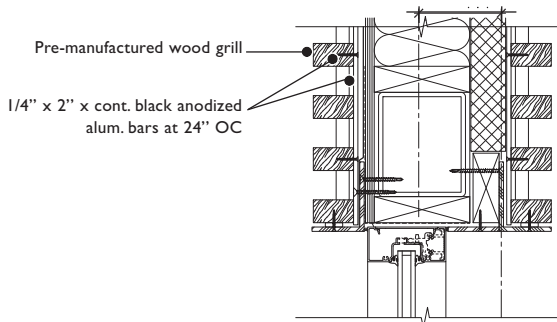

Detail B: Wood grate at window head

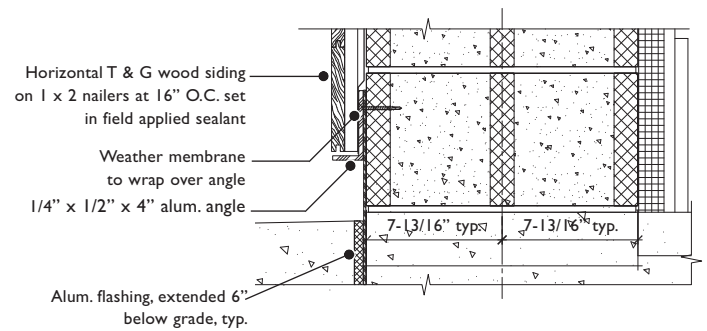

Siding at ground detail



Western Red Cedar Specification

Grade: NLGA A & Better Clear

Profile: rectangular rails, dowels

Size: 1-1/4in x 2-1/4in (32x58mm) rails at 3in (76mm) centers

1/2 in (13mm) dowels at 12in (305mm) centers

Fixing: cross piece backer fastened to structure with No. 8 screws

Finish: clear urethane



The rendering of the simple forms in beautiful and durable natural materials evokes a sense of quality and permanence that was a key design goal. Western Red Cedar grilles provide a rain screen while visually accentuating the sense of lightness, transparency and horizontality of the architecture. Views to and from the new pavilion create a focus for the activities of the park.



CLIENT City of South San Francisco

ARCHITECT Marcy Wong and Don Logan Architects

STRUCTURAL ENGINEER Umerani Associates

MECHANICAL ENGINEER MDS

ELECTRICAL ENGINEER Int-Elect Engineers

LANDSCAPE ARCHITECT Gates & Associates

GENERAL CONTRACTOR Rodan Builders

PHOTOGRAPHY Billy Hustace Photography; Sharon Risedorff
Photography

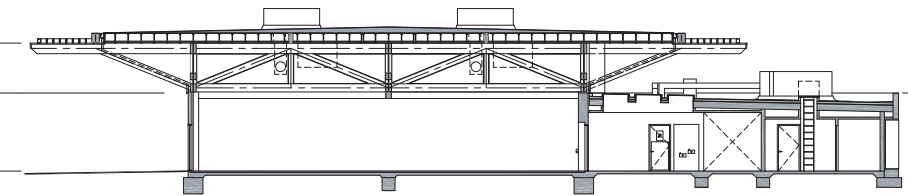

Section

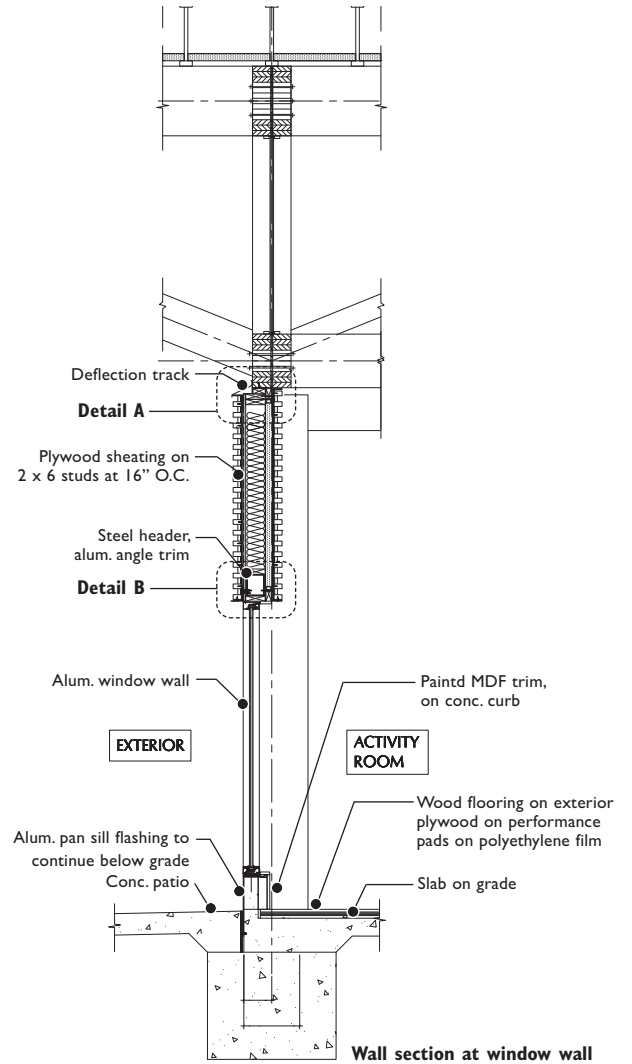

THE ROOF OVERHANGS DEFINE A TRANSITIONAL AREA BETWEEN INSIDE AND OUTSIDE, WHILE THE WESTERN RED CEDAR SUN SCREENS CREATE A VISUAL CONNECTION TO THE LANDSCAPE. THE LIGHT WOOD STRUCTURE HOVERS ABOVE THE SOLID BASE OF BASALT STONE.



- A Gallery/ reception
- B Board room
- C Wedding rental
- D Visitor's center
- E Auditorium vestibule
- F Auditorium
- G Water channel
- H Cleansing biotope
- I Rain-water collection

Floor plan



WINNER - 2008 WESTERN RED CEDAR
ARCHITECTURAL DESIGN AWARDS (JURY AWARD)

QUEENS BOTANICAL GARDEN VISITOR & ADMINISTRATION CENTER

QUEENS, NEW YORK, USA



The Queens Botanical Garden is a nexus of botanical and cultural exploration for one of the most ethnically diverse neighbourhoods in the United States, Queens County. The new Visitor & Administration Center is a built extension of the Garden's mission: to demonstrate environmental stewardship while celebrating the cultural connections between people and plants.

From the inception of the project, principles of sustainability led the design process. Water, a natural element significant to all cultures, is re-introduced throughout the site, unifying building and landscape.

The Center is composed of three interconnected spaces: a forecourt and dramatic roof canopy, a central reception and administration building clad in Western Red Cedar; and an auditorium space tucked into the landscape itself, sheltered by a sloping green roof. Additional sustainable elements include solar panels, a geo

THE CENTER COMPRISES THREE INTERCONNECTED COMPONENTS A FORECOURT SHELTERED BY A DRAMATIC ROOF CANOPY, A CENTRAL ADMINISTRATION AND RECEPTION BLOCK CLAD IN WESTERN RED CEDAR AND AN AUDITORIUM TUCKED INTO THE LANDSCAPE ITSELF.

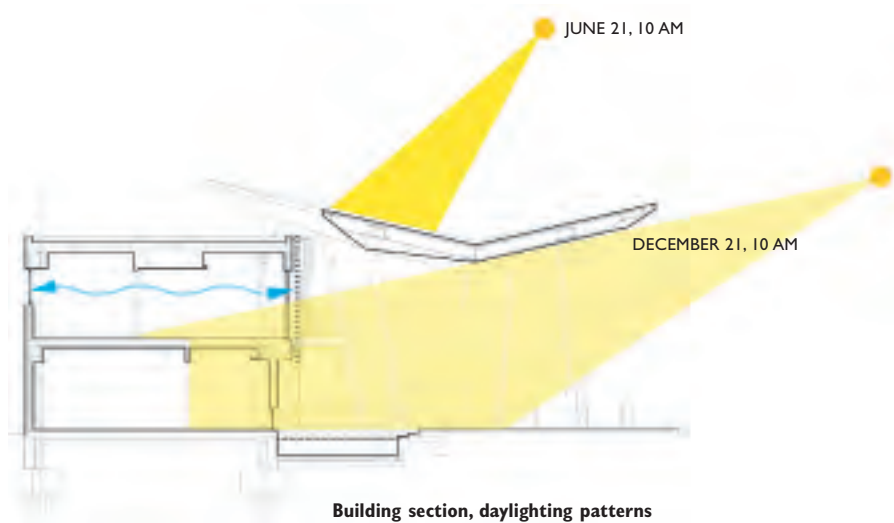

Building section, daylighting patterns



AS AN IMPORTANT SYMBOL IN MANY CULTURES, WATER HAS BEEN CONSCIOUSLY REINTRODUCED TO THE SITE IN A VARIETY OF WAYS. OTHER IMPORTANT ELEMENTS INCLUDE LIGHT CAREFULLY FILTERED AND CONTROLLED BY SCREENS, AND EARTH- WHICH FORMS THE GREEN ROOF OF THE AUDITORIUM.



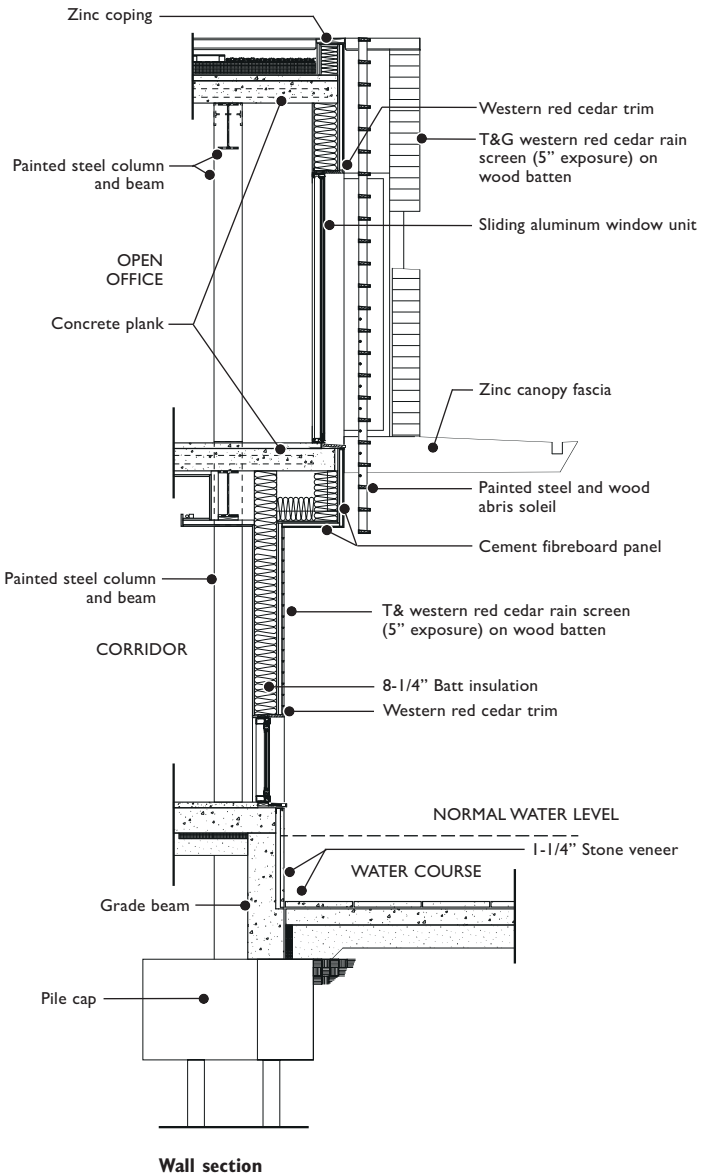

CLIENT Queens Botanical Garden
 ARCHITECT BKS Architects LLP
 STRUCTURAL/CIVIL ENGINEER Weidinger Associates
 MECHANICAL/ELECTRICAL ENGINEER M-E-P Design
 ENVIRONMENTAL BUILDING CONSULTANT Viridian Engineering
 Environmental, LLC,
 LANDSCAPE ARCHITECTS Atelier Dreiseitl
 GENERAL CONTRACTOR Stonewall Contracting Corporation
 PHOTOGRAPHER Jeff Golberg/Esto



Western Red Cedar Specification

Grade: NLGA A & Better Clear (vertical grain)
 Profile: tongue and groove
 Size: finished 1x6in (19mm x 140mm)
 Fixing: concealed nails to vertical battens
 Finish: sanded smooth for clear wood finish

THE USE OF NATURAL MATERIALS SUCH AS WESTERN RED CEDAR, AND THE CHOICE OF FORMS SYMPATHETIC TO THE SURROUNDING LANDSCAPE INTEGRATE THIS SUSTAINABLY DESIGNED BUILDING INTO ITS PARK SETTING.

thermal system, grey water and storm water management systems. The wood products used in the building are certified, reclaimed, recycled and harvested/manufactured regionally where possible. Domestically sourced, Western Red Cedar was chosen for its performance and aesthetic characteristics. Cedar is durable and stable, and will naturally weather over time, a reflection of the passage of seasons in the surrounding garden landscape.

The project goal was to not only conserve and generate energy, but to utilize the Center itself as a "teaching tool" for visitors. The new building creates energy by harvesting nature and reduces energy use by design. Interactive touch screen displays, tours and workshops allow visitors to experience and monitor the building's solar and geothermal systems in real time. Lighting system sensors automatically adjust to natural light conditions and occupancy levels. Operable windows allow for natural ventilation of all interior spaces. Overall the new Queens Botanical Garden Visitor and Administration Center will realize a substantial energy cost saving compared to a typical building of its size and type, and will serve as an interactive model for living and building in harmony with the environment.



Elevation





RICHMOND GATE RESIDENCES

VICTORIA, BRITISH COLUMBIA, CANADA

The setting for this project is a confluence of streets which wind around adjacent hills in suburban Victoria BC. The site marks the boundary between established single family residential neighbourhoods and the more institutional scale of care homes, offices and strip malls.

The geometry of the site and the blend of uses created a setting of varied scale, materials and building orientations, in which the interconnection between the public and private realms was of paramount importance.

The project is divided into three separate buildings: two condominium buildings of 4 storeys and a row of two storey townhouses. The different scales and careful placement of these buildings on the sloping site facilitates the transition from neighbouring institutional structures on one side, to single family

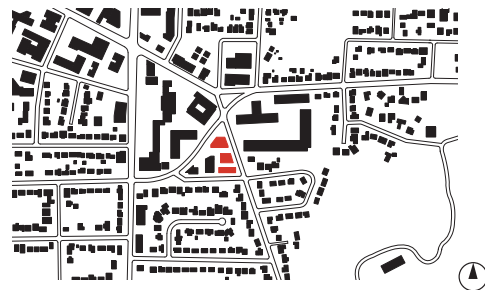

Location plan

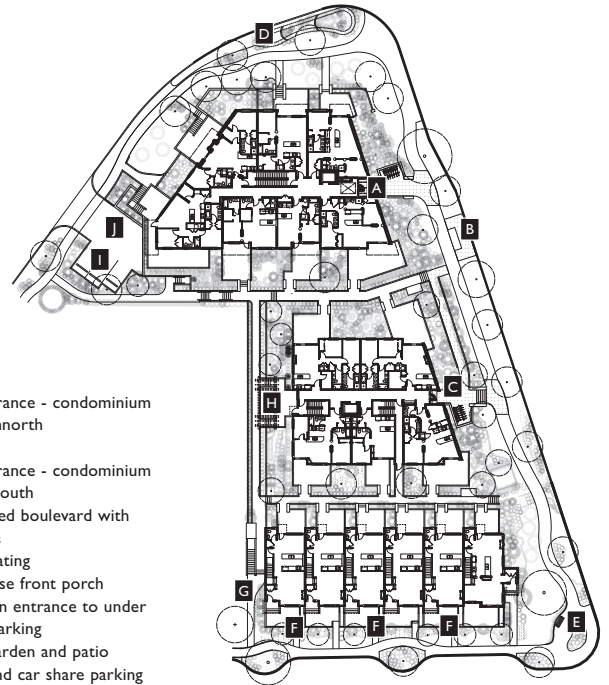

- A Main entrance - condominium building north
- B Bus stop
- C Main entrance - condominium building south
- D Landscaped boulevard with bioswales
- E Public seating
- F Townhouse front porch
- G Pedestrian entrance to under ground parking
- H Shared garden and patio
- I Visitor and car share parking
- J Stormwater retention tank under driveway

Site/ ground floor plan



residences on the other. Viewed from the public domain, the building forms follow the triangular shape of the site and so define the street edge. Pedestrian walkways thread between the buildings, creating semi private courtyards and dividing the composition, so reducing the visual impact of the development.

Built on the western slope of Mount Tolmie, a foothill park with a distinctive Garry Oak and Arbutus woodland, the buildings were designed to resonate with the colours and textures of the natural context. The bases of the buildings are clad in local stone, the upper portions in Western Red Cedar siding.

Wood was used for this project for its economy and aesthetic qualities, but also because of its environmental benefits, which include low embodied energy, and a reduced carbon footprint. The exterior wall is detailed as a ventilated rainscreen assembly



GREAT CARE HAS BEEN TAKEN NOT ONLY IN THE DESIGN AND DETAILING OF THE BUILDINGS, BUT ALSO IN THE DESIGN AND DETAILING OF THE SURROUNDING SPACES. PATHS REFLECT EXISTING DESIRE LINES WITHIN THE NEIGHBOURHOOD IN ESSENCE CREATING A PUBLIC RIGHT OF WAY ACROSS THE SITE.

THE DEVELOPMENT COMPRISES APARTMENT AND TOWNHOUSE BUILDINGS OF DIFFERENT HEIGHTS, EFFECTING A TRANSITION OF SCALE BETWEEN INSTITUTIONAL AND RESIDENTIAL NEIGHBOURHOODS. ALL THE STRUCTURES ARE CLAD IN WESTERN RED CEDAR.

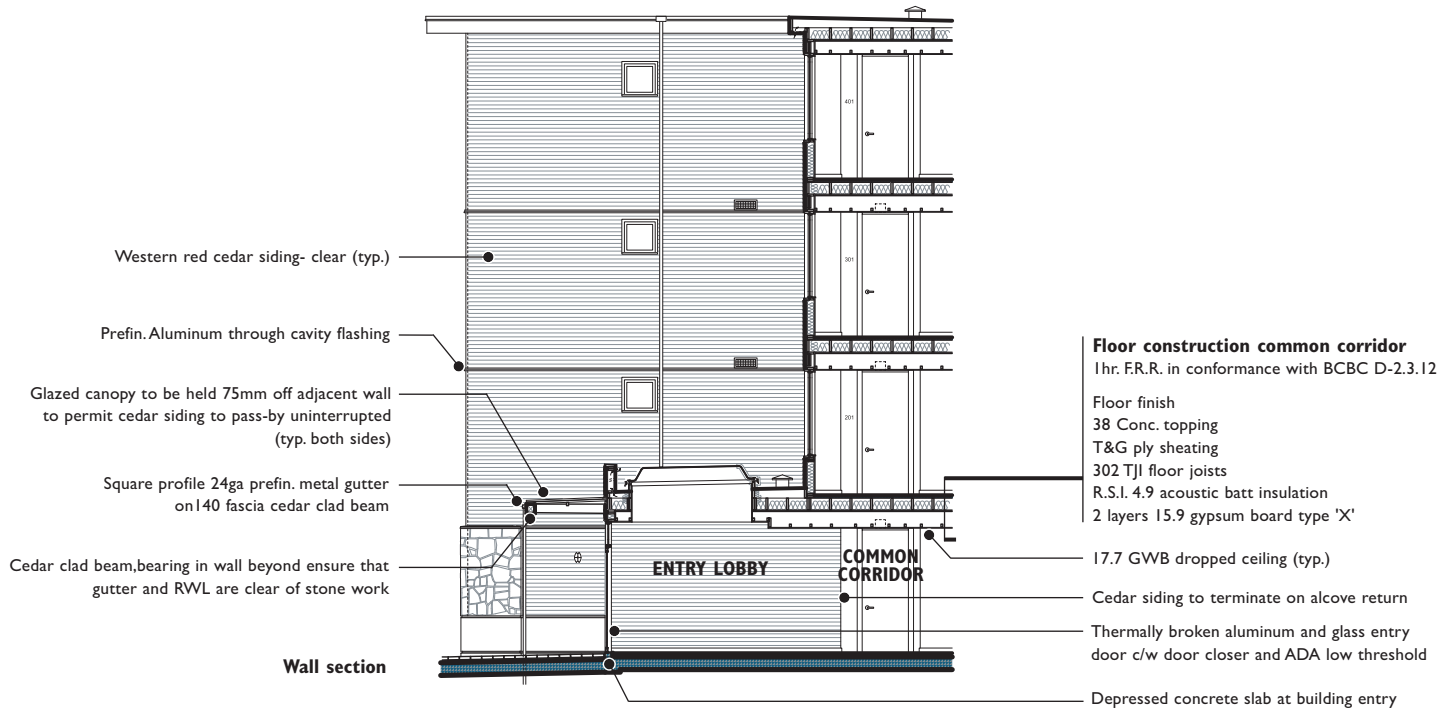

Western Red Cedar Specification

Siding and Soffits

Grade: R-List # 2 Clear

Profile: tongue and groove with V joint installed back side out

Size: surfaced 1x6in (19x140mm)

Fixing: concealed nails

Finish: semi-transparent stain

Miscellaneous

Townhouse decorative lattices: surfaced 1x2in (19x38)

horizontals, surfaced 1x1in (19x19mm) verticals

Trim pieces: surfaced 1x2in (19x38mm)

Window surrounds and sills: surfaced 2x material (38mm)

Glazed canopy joists & fascias: surfaced 2x6in (38x140mm)





detail with the milled reverse side of the boards exposed. This detail produces a flush surface that gives the buildings a more refined and contemporary expression

Named to acknowledge its location at the entrance to an established neighbourhood, the Richmond Gate Residences have provided a mid-density development that is both sympathetic to its natural setting and supportive of the surrounding community.

THE CEDAR CLAD BUILDINGS STAND ON PLINTHS OF LOCAL STONE. THE SAME MATERIAL IS USED ON THE END ELEVATION OF THE TOWNHOUSES, COMPLEMENTING IN COLOUR AND TEXTURE THE PLAIN CEDAR SURFACES, AND CONNECTING VISUALLY TO THE ROCKY OUTCROPS ON NEARBY MOUNT TOLMIE.

CLIENT Richmond Gate Properties Inc.
ARCHITECT D'AMBROSIO architecture + urbanism
STRUCTURAL ENGINEER John Bryson and Partners
MECHANICAL ENGINEER Avalon Mechanical Consultants
ELECTRICAL ENGINEER Triumph Engineering Consulting
BUILDING ENVELOPE Chatwin Engineering
LANDSCAPE ARCHITECT LADR Landscape Architects Inc.,
GENERAL CONTRACTOR Homewood Constructors Ltd
PHOTOGRAPHY photo 4 and 7, D'AMBROSIO architecture + urbanism; photo 1, 2, 3, 5, 6, Jonathan Taggart



THE LIBRARY SITS ON A SLOPING SITE ADJACENT TO THE LARGEST PARK IN WHISTLER VILLAGE, AND WITH VIEWS TO NEARBY MOUNTAINS. THE USE OF WOOD AND STONE CONNECTS THIS CONTEMPORARY STRUCTURE TO ITS SURROUNDINGS AND TO THE MORE TRADITIONAL ARCHITECTURE OF THE VILLAGE.

WHISTLER PUBLIC LIBRARY

WHISTLER, BRITISH COLUMBIA, CANADA

The resort municipality of Whistler is nestled in the rugged Coast Mountains north of Vancouver, BC. Its new 15,000sf (1,400m²) library building, completed in 2008, provides state of the art facilities and a new civic presence for what is the municipality's only public library. The project aspires to connect the sense of imagination, contemplation and community found in the world of books with the grand scale of the natural surroundings, while offering a new approach to the design of mountain architecture.



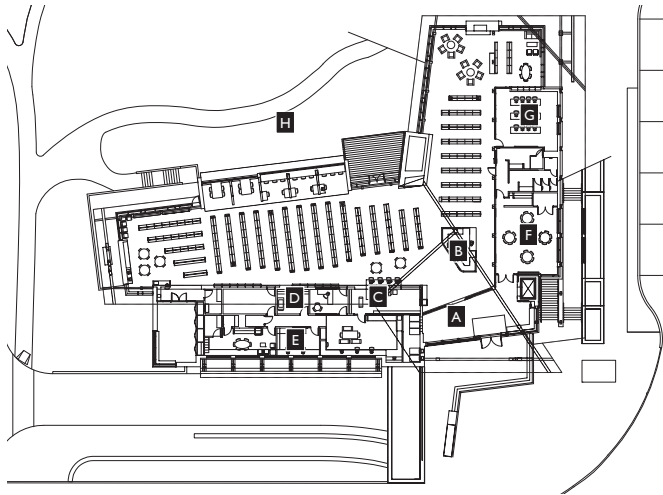

- | | | | |
|---|------------------|---|-------------------------|
| A | Entry vestibule | E | Group study |
| B | Circulation desk | F | Outdoor reading terrace |
| C | Patron service | G | Multipurpose room |
| D | Staff room | H | Offices |

Floor plan

The form of the building responds to solar orientation and the conditions of its site, mediating between the urban edge of Whistler's 'village stroll', the adjacent wooded park and the mountains beyond. Rusticated board form concrete and basalt stone cladding were used on key vertical elements like the fire place and elevator core to anchor the building to its mountain site, while WRC cladding and trim were used to provide a warm counterpoint to these elements and to connect the building to the more traditional architecture of the village.

On the north elevation bevelled siding was used around the study carrels to create a sense of intimacy conducive to contemplation and study, while on the west elevation a larger custom

THE SHALLOW ROOF IS DESIGNED TO RETAIN SNOW, WITH UPTURNED EAVES TO PREVENT INADVERTENT SHEDDING AT POINTS OF ENTRY TO THE BUILDING. DIAGONAL GLULAM STRUTS WITH DISCREET PIN CONNECTIONS ELEGANTLY EXPRESS HOW SNOW AND OTHER LOADS ARE CARRIED TO THE GROUND.





CLIENT Resort Municipality of Whistler
 ARCHITECT Hughes Condon Marler Architects
 STRUCTURAL ENGINEER Fast + Epp Structural Engineers
 MECHANICAL ENGINEER Stantec Engineering
 ELECTRICAL ENGINEER Acumen Engineering
 LANDSCAPE ARCHITECT Phillips Farevaag Smallenberg
 GENERAL CONTRACTOR Whistler Construction Company
 PHOTOGRAPHY Nic Lehoux, Martin Tessler

profile channel siding with reveals was used to provide a scale relating to the glulam beams and columns on the reading terrace. In the parkade and public stair, a v groove cedar soffit was used over circulation areas to create a welcoming feel.

Finally, the natural preservatives found in cedar and the fact that western red cedar is a locally produced material made the decision to use cedar easy for this sustainability driven project.

WESTERN RED CEDAR IS USED FOR THE SOFFIT AT THE ENTRANCE TO THE PARKING GARAGE, AND FOR CLADDING OVER MUCH OF THE BUILDING. SOLID HEMLOCK CEILINGS BRING THE WARMTH OF WOOD TO THE INTERIOR, WHICH ALSO BENEFITS FROM AMPLE DAYLIGHT AND VIEWS TO THE ADJACENT PARK.

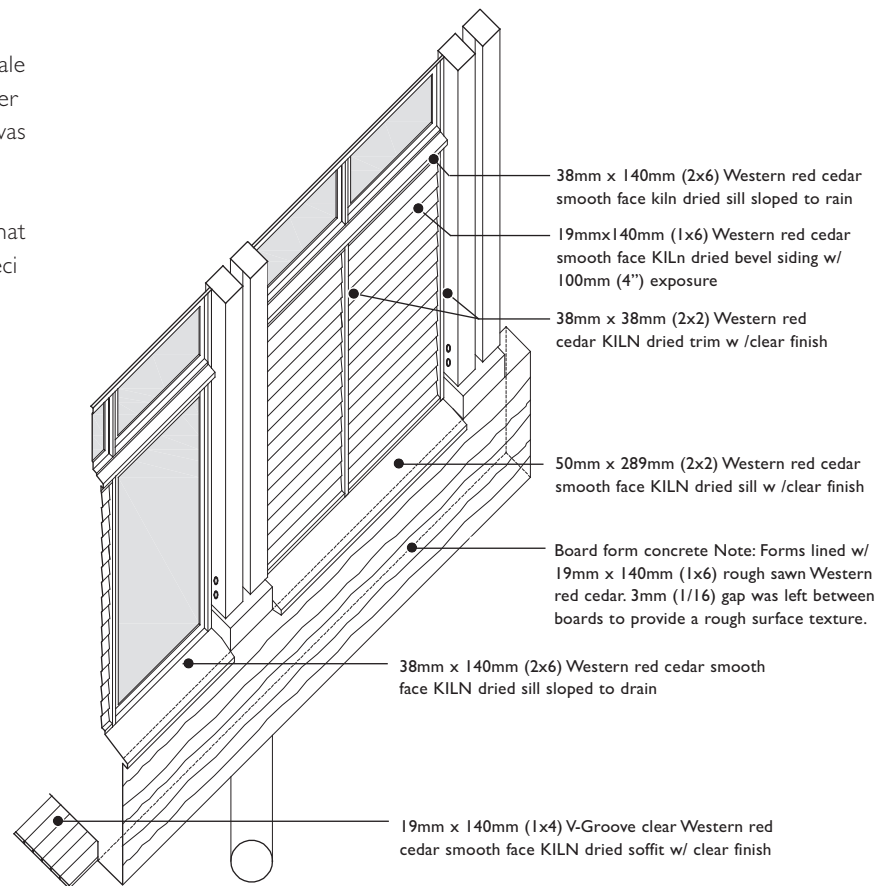

Wall detail

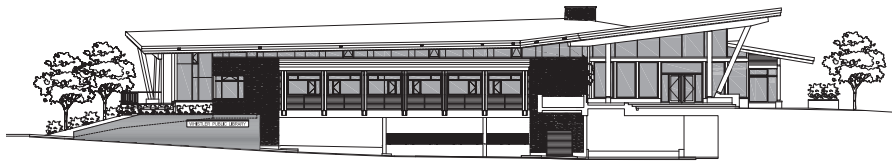

South

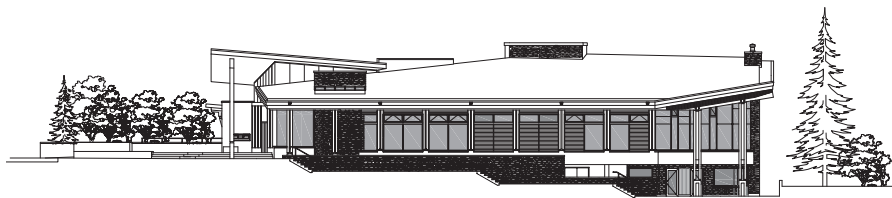

Main street elevations

East

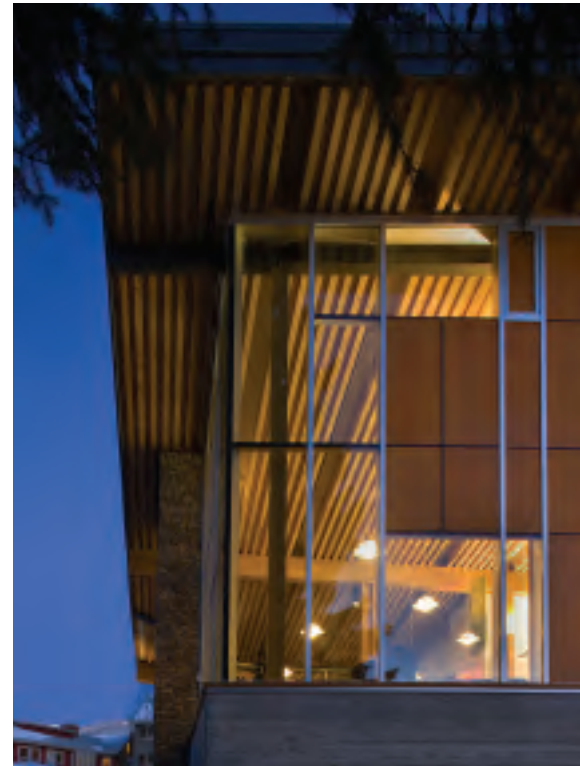



Western Red Cedar Specification

Siding:

Grade: NLGA A & Better Clear

Profile and Size: surfaced 1x4in (19 x 89mm) channel siding

surfaced 1x6in (19 x 140mm) bevel siding

surfaced 3/4x8in (19 x 190mm) channel siding custom profile

Fixing: finishing nails

Finish: low VOC satin finish - natural

Soffits:

Grade: NLGA A & Better Clear

Profile: tongue and groove

Size: surfaced 1x4in (19 9mm)

Fixing: finishing nails

Finish: low VOC satin finish - natural

Fascia Boards

Grade: NLGA A Select Knotty (max. 10% B)

Profile: rectangular

Size: finished 2x8in (38 x 198mm)

Fixing: exterior machine screws in pre-drilled holes

Finish: low VOC satin finish - natural colour



