

BUILDING A PERGOLA

Complete with cozy bench seating, this beautiful Western Red Cedar pergola will instantly define and enhance your outdoor living space. The L-shaped, two-level layout is specifically designed to offer several points of visual interest, provide shade on a hot day, and create a welcoming atmosphere for entertaining guests as well as an open-air retreat for relaxing after a hard day's work. And because you've chosen a durable wood like Western Red Cedar, which is naturally resistant to rot and decay, this backyard beauty will last you a very long time. So let's get started!

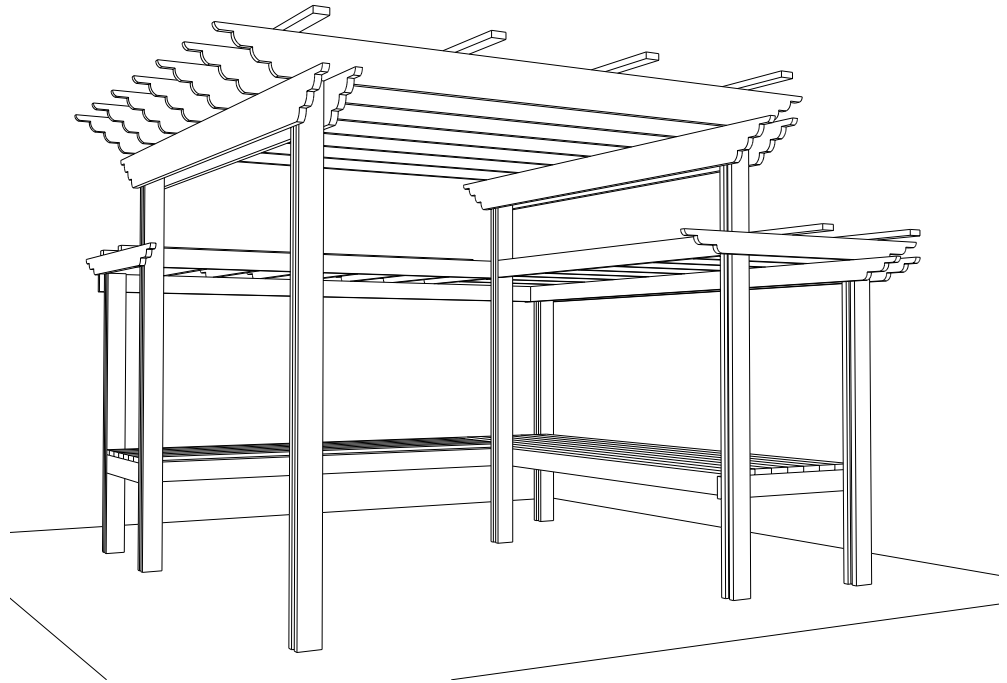

DESIGNED BY MYFIXITUPLIFE'S MARK AND THERESA CLEMENT FOR REAL CEDAR

WHAT YOU'LL NEED

PART #	DESCRIPTION	FINISHED SIZE			SIZES	MATERIAL	QTY
		T	W	L			
MAIN PERGOLA							
A	POST	1 1/2"	5 1/2"	*	2X6X16	WR CEDAR	8
B	POST	1 1/2"	3 1/2"	*	2X4X16	WR CEDAR	4
C	GIRDERS	1 1/2"	9 1/2"	152"	2X10X14	WR CEDAR	4
D	RAFTERS	1 1/2"	9 1/2"	156"	2X10X14	WR CEDAR	7
E	PURLINS	1 1/2"	3 1/2"	152"	2X4X14	WR CEDAR	4
SEATING AREA							
F	POST	1 1/2"	5 1/2"	**	2X6X12	WR CEDAR	6
G	POST	1 1/2"	3 1/2"	**	2X4X12	WR CEDAR	3
H	GIRDERS	1 1/2"	5 1/2"	192"	2X6X16	WR CEDAR	2
I	RAFTERS ENDS	1 1/2"	5 1/2"	79"	2X6X8	WR CEDAR	2
J	RAFTERS	1 1/2"	5 1/2"	62"	2X6X6	WR CEDAR	17
K	PURLINS	1 1/2"	3 1/2"	152"	2X4X14	WR CEDAR	2
L	PURLINS	1 1/2"	3 1/2"	117 1/2"	2X4X10	WR CEDAR	2
M	FRAME	1 1/2"	5 1/2"	120"	2X6X10	WR CEDAR	1
N	FRAME	1 1/2"	5 1/2"	111"	2X6X10	WR CEDAR	1
O	FRAME	1 1/2"	5 1/2"	152"	2X6X14	WR CEDAR	1

CONTINUES ON PAGE 2

PART #	DESCRIPTION	FINISHED SIZE			SIZES	MATERIAL	QTY
		T	W	L			
BENCH							
P	BENCH TOP RIGHT	1 1/2"	5 1/2"	15 1/2"	2X6X14	WR CEDAR	7
Q	BENCH TOP BACK	1 1/2"	5 1/2"	120"	2X6X10	WR CEDAR	7
R	BENCH BRACING	1 1/2"	5 1/2"	34 1/2"	2X6X3	WR CEDAR	3
S	BENCH BRACING	1 1/2"	5 1/2"	33"	2X6X3	WR CEDAR	3
T	BENCH BRACING	1 1/2"	5 1/2"	36"	2X6X3	WR CEDAR	1
U	BENCH BRACING	1 1/2"	5 1/2"	47"	2X6X4	WR CEDAR	1
V	BRENCH FRAME	1 1/2"	5 1/2"	148 1/2"	2X6X14	WR CEDAR	2
W	BRENCH FRAME	1 1/2"	5 1/2"	161 1/2"	2X6X14	WR CEDAR	1

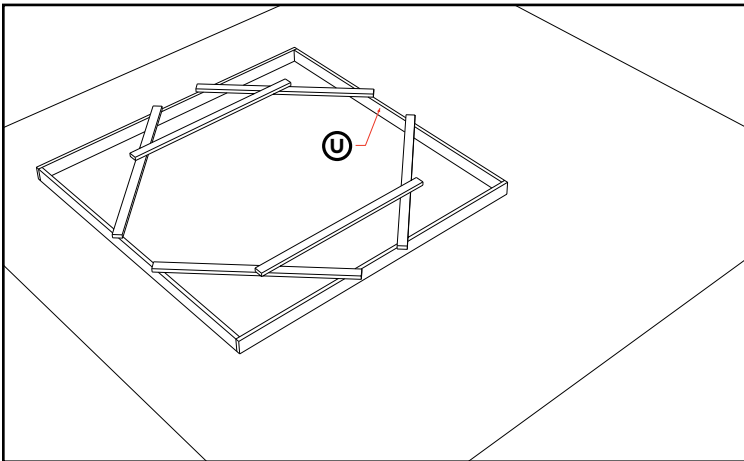

STEP 1 - Build Template Frame

Using four pieces of 2x6x10 timbers, build a full-size, level template. Make sure that it's dead-on square to avoid any problems when it comes to installing permanent pieces. Attach angle bracing in each of the corners so you have something to grab on to when you move it. Keep in mind, this frame is intended for the main pergola posts to fit plumb against the inside the corners.

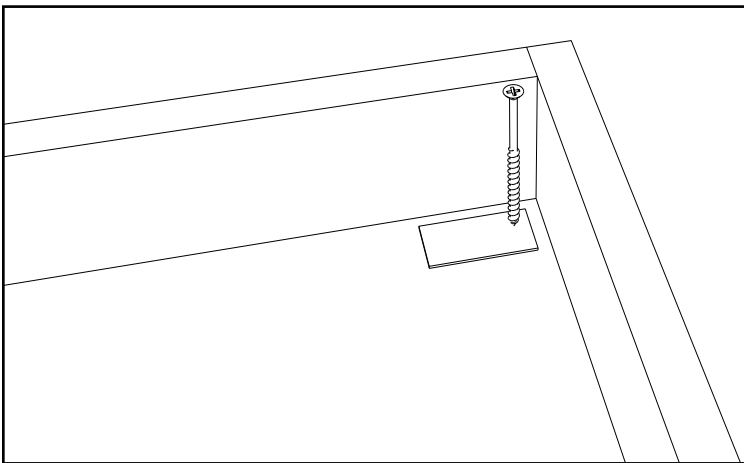

STEP 2 - Mark and Level Template

Tweak the template's position with anything straight within 10 feet or so (i.e. fence, deck or patio). Trace an outline of the template so you know exactly where to put it when it's time to put it back. Then in each corner, place a piece of tape on the ground and stick a screw in to mark where the center of each post will be placed.

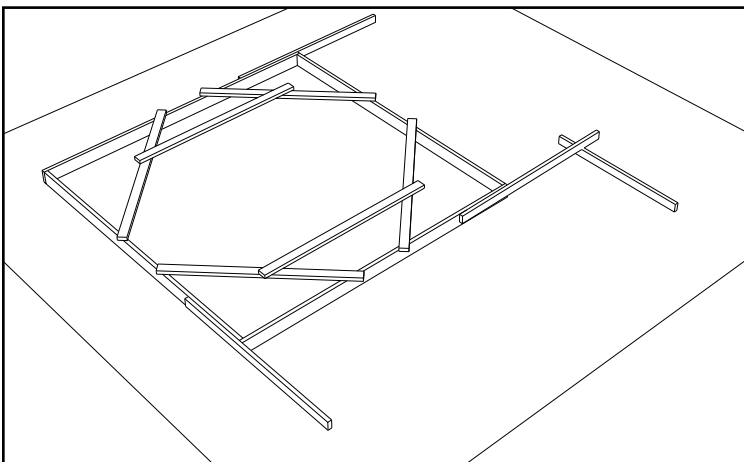

STEP 3 - Extend Template

Attach outriggers from the template to mark proper placement of the second-level pergola posts.

CEDAR PRO TIP:

If you let Western Red Cedar weather naturally, it will eventually turn to a beautiful silvery grey patina. But if you do choose to stain your pergola, stain all six sides of each timber BEFORE installation.

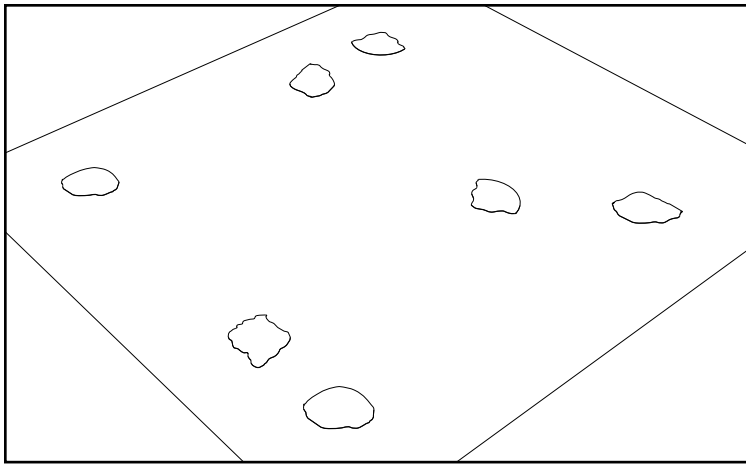

STEP 4 - Dig Post Holes

Set the template aside using the angle bracing as handles. Spray-paint a 3-ft. wide X through the center of each post location. Then use a garden spade to score the outline of 16x16 post holes and then cut into the sod. Posts should be set 24-36 inches below grade. Switch to long-handled shovel to dig and move the dirt. But use a digging bar if you need to cut roots, shave the edges of the hole straight and/or break up tough soil.

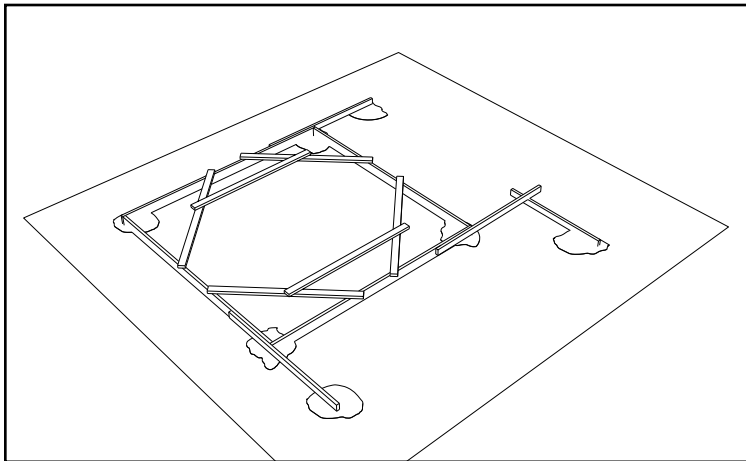

STEP 5 - Return Template

Put the template back into position. If you have a slope, block it up level (careful not to disrupt the template position).

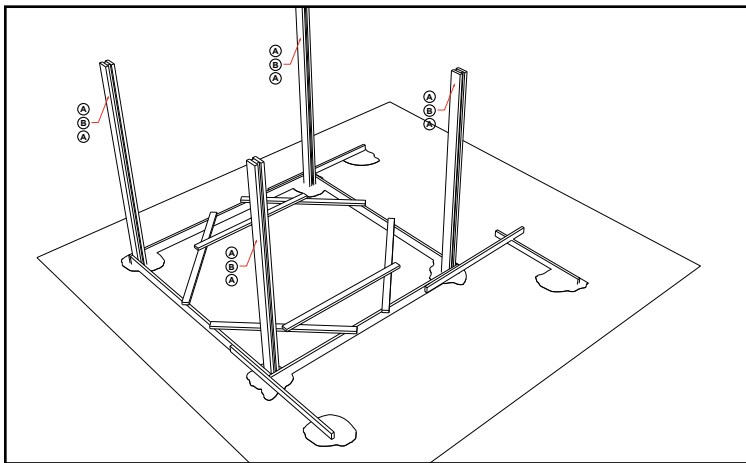

STEP 6 - Build and Place Main Posts

Screw the 2x4 in the center of the first 2x6. Then screw the second 2x6 to the 2x4 with 3-inch deck screws. In other words, screw B to A, then A(2) to B, using two screws, about 3/4-inch in from each side, about every 16-inches along the board.

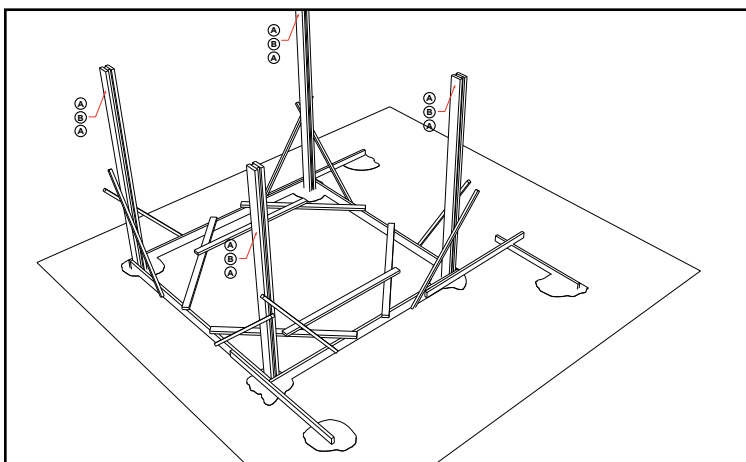
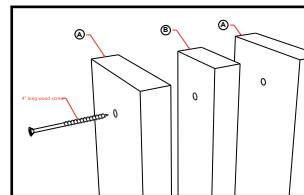

STEP 7 - Secure and Set Main Posts

Secure posts to the template with crosspieces, keeping fasteners out of sight as much as possible. Mix fast setting concrete in a wheelbarrow to a chunky peanut butter consistency. Pour that in the hole around the base of each post. Let dry over night. Then pack dirt down lightly (don't smash) with a sledgehammer every six inches or so until the holes are filled and all the air has been pushed out of the dirt.

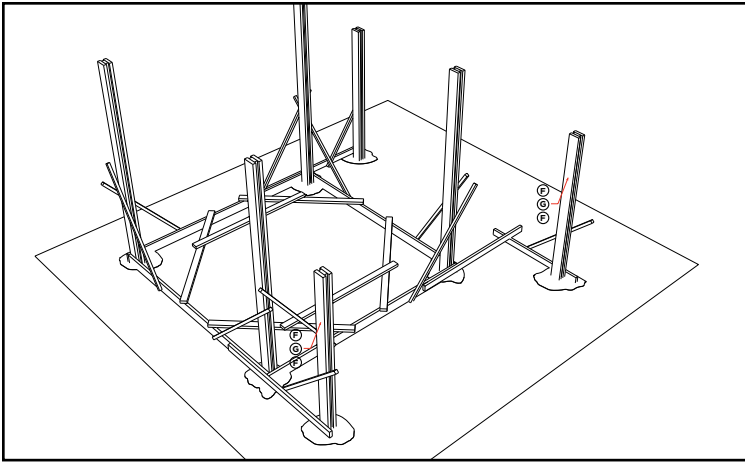

STEP 8 - Build and Set Smaller Posts

Make second level posts by sandwiching one (G) 2x4 between two (F) 2x6s. Place these completed small pergola posts in holes and fill in with cement (see above). Let dry overnight. Then remove template and bracing.

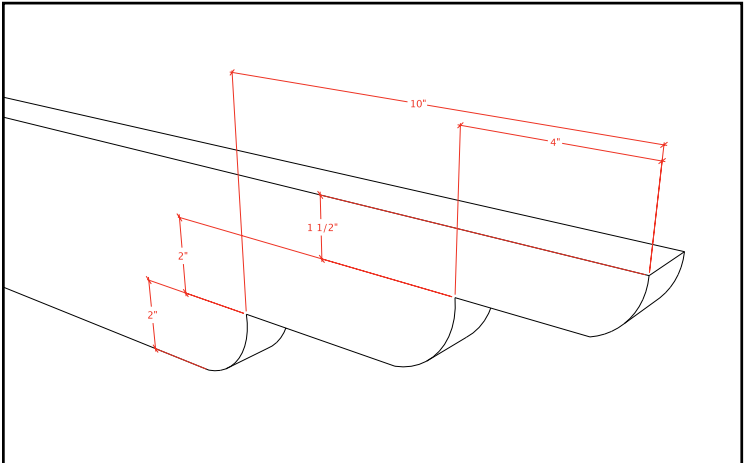
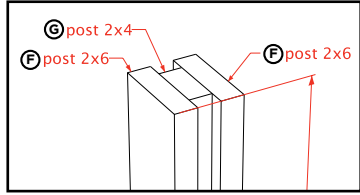

STEP 9 - Customize Rafters & Girders

Uses a pattern to map out desired tail ends. Then cut one girder as a pattern for all other main pergola girders & rafters. Do likewise with a smaller pattern for the secondary pergola rafters and girders.

SEE PATTERNS ON PAGE 7 & 8

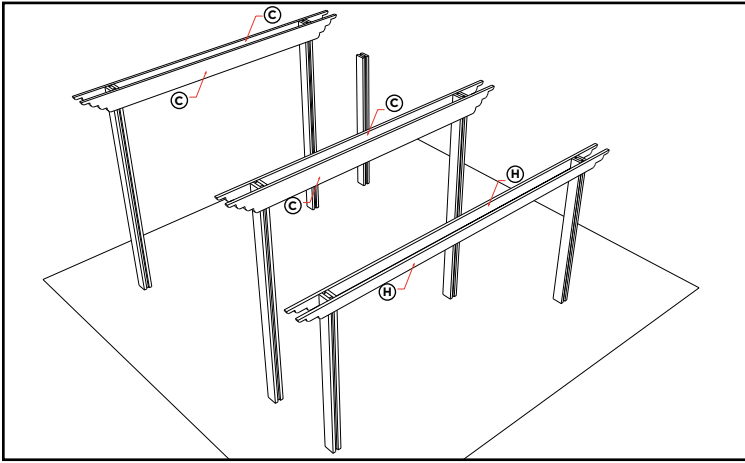

STEP 10 - Begin Assembly

Begin assembly by installing four (C) 2x10 girders on the main pergola and then two (H) 2x6 girders on the secondary pergola.

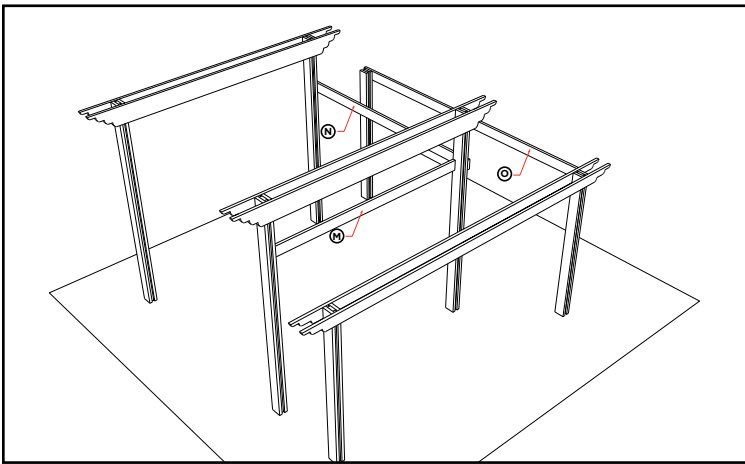

STEP 11

Install two (M&N) 2x6s and one (O) 2x6 girders around seating area.

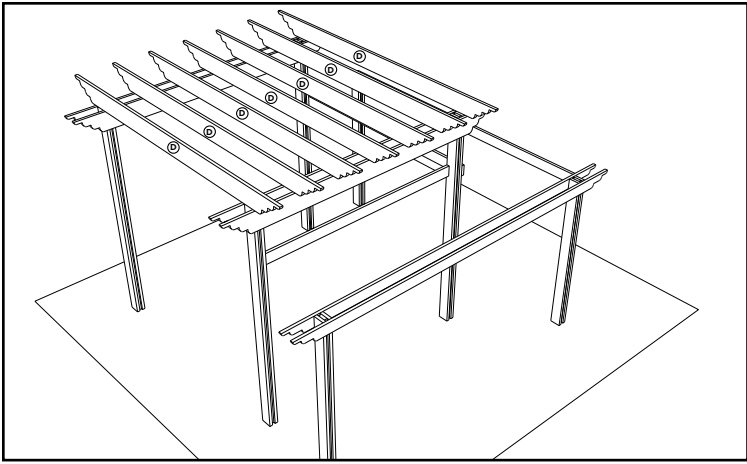

STEP 12

Install seven (D) 2x10 custom cut rafters on main pergola.

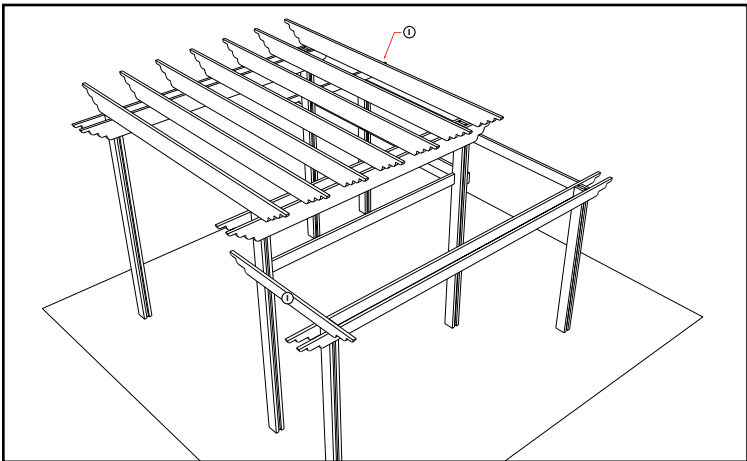

STEP 13

Install two (I) 2x6 rafter end pieces onto second-level pergola.

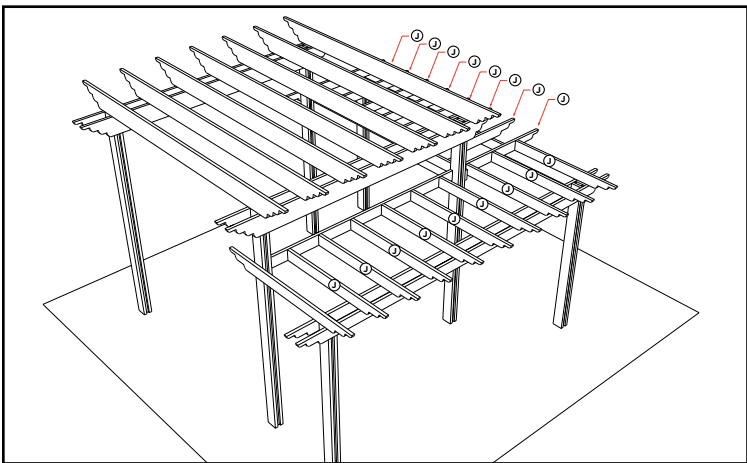

STEP 14

Install seventeen (J) 2x6 rafters onto second level pergola.

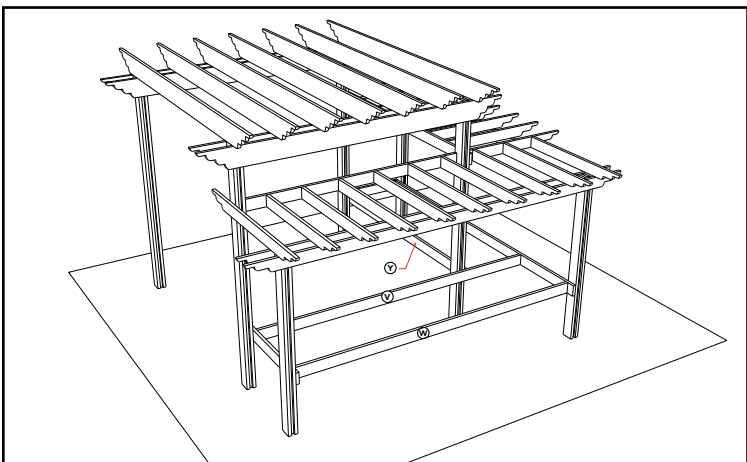

STEP 15

Install three (V&W) 2x6 and one (Y) 2x6 bench frames.

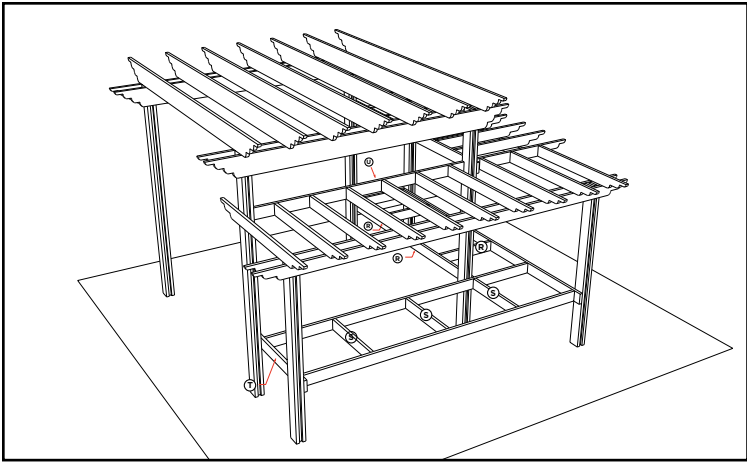

STEP 16

Install six 2x6 (R and S), one 2x6 (T), and one (U) 2x6 bench joists 24" on center.

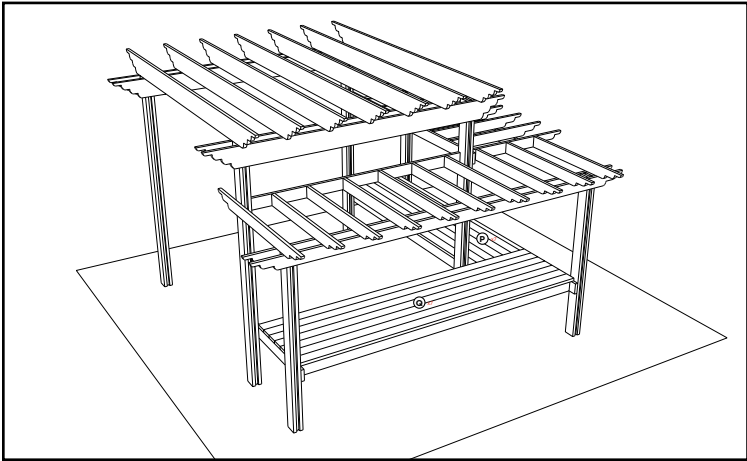

STEP 17

Install seven (P) 2x6 decking timbers on top right bench and seven (Q) 2x6 on top back bench.

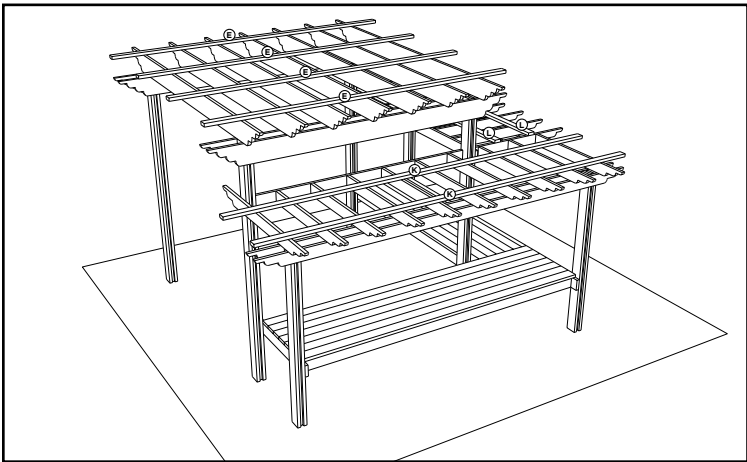
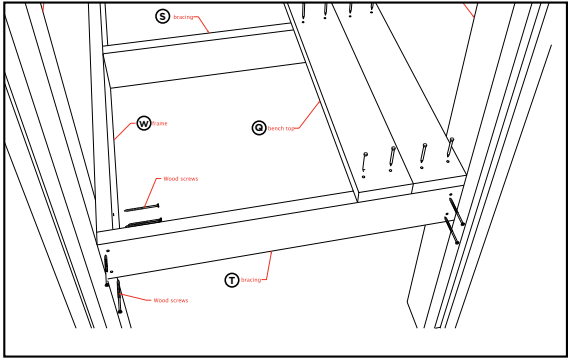
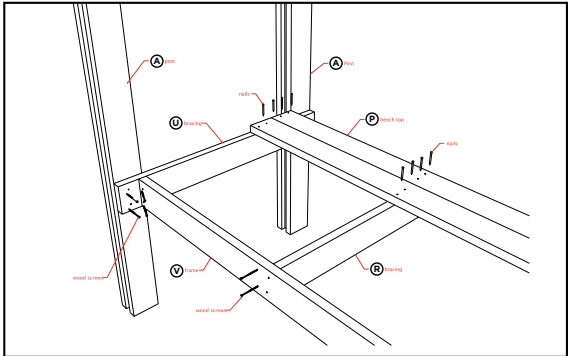

STEP 18

Top with four (E) 2x4 purlins on main pergola. Then two (K) 2x4 and two (L) 2x4 purlins on the secondary pergola.

TEMPLATE: Rafter Main Pergola

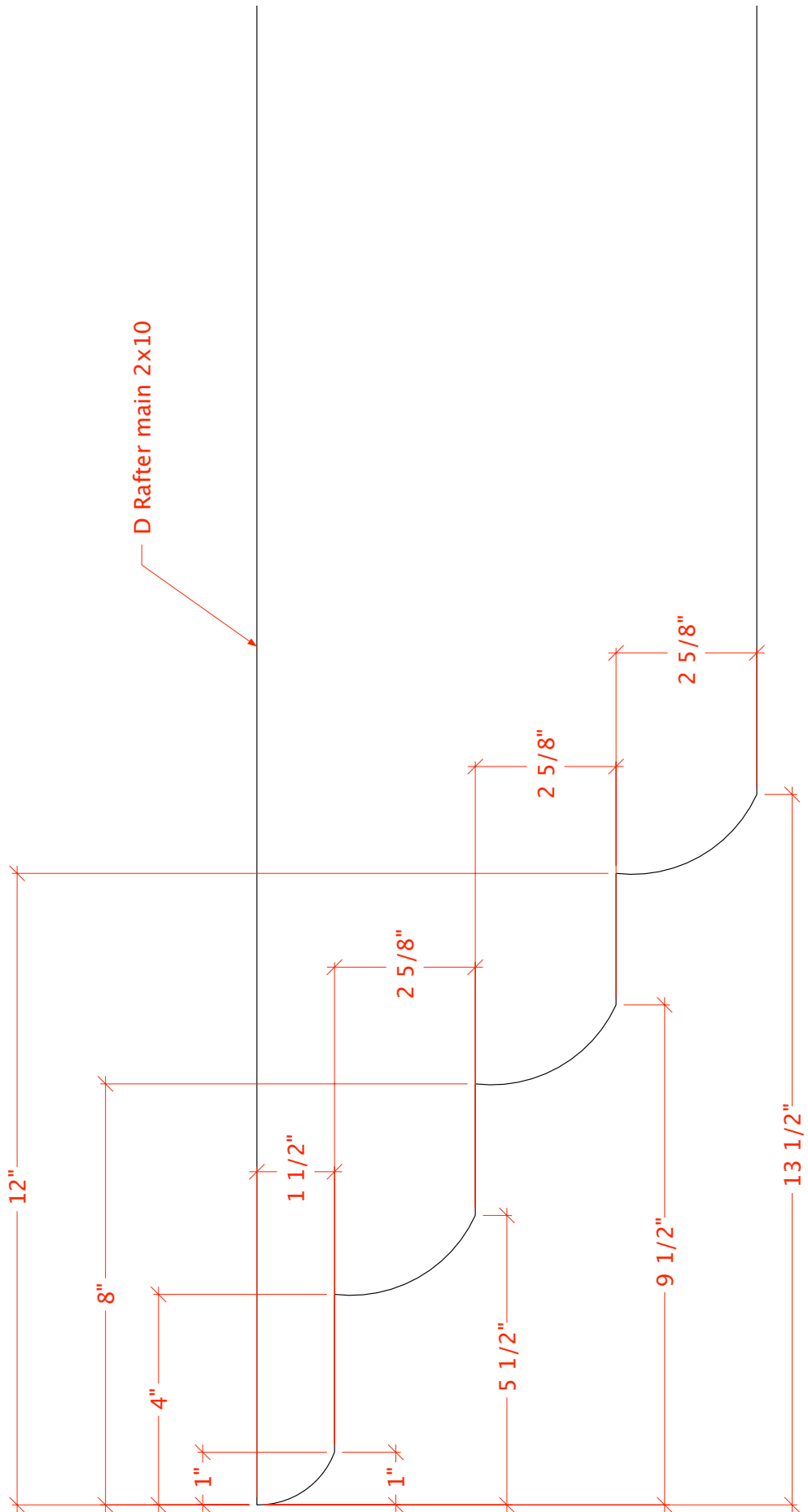

TEMPLATE: Girders Bench Area

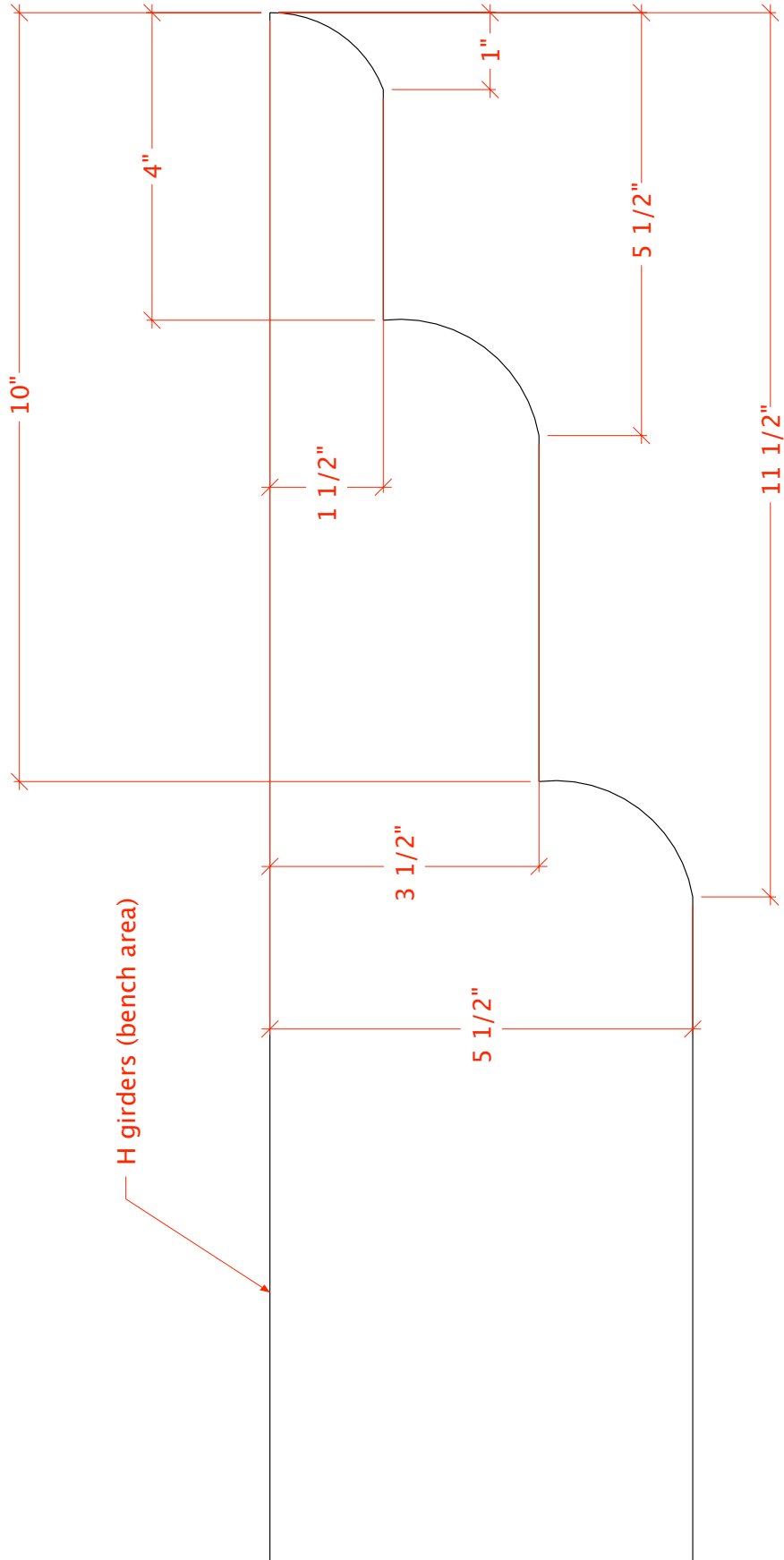

For more plans, information and instructional videos visit
<http://www.realcedar.com/outdoor/plans/>



NOTE: Before you start digging, check with your local building department to make sure there are no underground utilities or cables.

BEST PRACTICE: If you plan on installing an outdoor structure close to your property line, Real Cedar recommends getting written consent from your neighbours.

Instructions are subject to local building codes, so it's always best to call your local building department before you begin construction. Also, Real Cedar is not responsible for any personal injury or property damage sustained in connection to these guidelines.