

Inspiration for the use of Western Red Cedar

THE CEDAR BOOK 2008



THE CEDAR BOOK 2008

Inspiration for the use of Western Red Cedar

THE CEDAR BOOK

Editor: Jim Taggart, Architext Communications
Design: Marie-Nicole Manseau, Janam Publications Inc.
Printing: Tri-Graphic



© 2008 Janam Publications Inc.
All Rights Reserved. Published October 2008
Printed in Canada

Library and Archives Canada Cataloguing in Publication

Taggart, Jim, 1956-
The cedar book 2008 : inspiration for the use of western red cedar /
Jim Taggart.

ISBN 978-0-9739122-4-1

1. Building, Wooden.
2. Western redcedar.
I. Title.

NA4110.T35 2008 694 C2008-905147-5

PRODUCED WITH THE GENEROUS SUPPORT OF



CO-SPONSORED BY:



WESTERN RED CEDAR LUMBER ASSOCIATION
(WRCLA) | WWW.REALCEDAR.ORG



WESTERN RED CEDAR EXPORT ASSOCIATION
(WRCEA) | WWW.WRCEA.ORG

Cover: Yale Sculpture Building an Gallery, photo: Peter Aaron/Esto

Welcome to the 2008 edition of The Cedar Book, a publication devoted to showcasing outstanding design applications incorporating the use of one of nature's most remarkable building materials – Western Red Cedar. Following on the success of the initial publication, numerous submissions of striking projects from around the world were received and the best of these are proudly featured inside.

Centuries ago, native peoples of the Pacific Northwest called the stately Western Red Cedar the “Tree of Life.” Its natural durability and versatility made it the preferred choice for building ocean-going canoes, post-and-beam houses, ceremonial dance masks and ancestral totem poles.

And for more than a century, discerning architects and builders across North America and around the world have enhanced their projects with this beautiful and durable material. Nature still knows best for, despite all efforts at imitation, no man-made product can match the performance qualities of Western Red Cedar. In today's environmentally sensitive world, the recognition of cedar as a renewable, sustainable and minimal carbon footprint product provides further assurance that it is the right choice.

This book illustrates the attributes that make Western Red Cedar a superior design and construction material in so many applications, as demonstrated in these sample projects. Good building design improves our quality of life, and Western Red Cedar has the performance history, handling and finishing qualities to make a special, lasting contribution.

If you are interested in having your project featured in the 2009 edition, you are invited to submit your project including photo, description and a profile of your firm to the association via email at info@wrcea.org. Select projects will also be featured on www.architect-gallery.com.

The Western Red Cedar Story

Western Red Cedar (*Thuja plicata*) is a contemporary, yet classic building material offering beauty, versatility, and durability. No man-made material can match Cedar's beauty and centuries of proven performance. Western Red Cedar is preferred where attractive appearance, superior performance and resistance to weather are important.

Cedar is the ultimate green building material. It is legally, responsibly and sustainably harvested in the publicly managed forests of British Columbia, Canada. Less than 1% of standing timber is harvested each year. For each tree harvested, three are replanted to ensure our forests will exist in perpetuity. Western Red Cedar has the least impact on the environment throughout its life cycle. It requires significantly less energy to produce than man-made alternatives and is biodegradable.

With its low density and high proportion of air spaces, Western Red Cedar is the best thermal insulator among the commonly available softwood species and is far superior to brick, concrete and steel. This helps keep buildings cool in the summer and reduce heating costs in the winter. Cedar has a very low shrinkage factor and is superior to all other coniferous woods in its resistance to warping, twisting and checking.

Western Red Cedar's naturally occurring compounds called "thujaplicins" act as natural preservatives - making the wood incredibly durable. Properly finished and maintained, cedar will deliver decades of trouble-free service.

There are few more versatile building materials than Western Red Cedar. For example, Western Red Cedar exterior siding comes in a spectrum of patterns. These are available in a wide range of widths and thicknesses offering further flexibility in design. Cedar siding is available in clear or knotty grades with smooth surfaced, combed or rough sawn finishes; flat grain and vertical grain. Cedar is free of pitch and with its high degree of dimensional stability it is the best of the softwoods for accepting paints, stains, oils and other coatings.

Not only does Western Red Cedar offer unparalleled performance, it is renowned for its distinctive beauty. Cedar provides an all natural beauty and warmth that cannot be duplicated by plastic, steel or composite products. A pleasing range of natural hues, tight grain patterns, and soft textures make it the choice of discerning homeowners, builders and architects.

Don't settle for anything less than the best. Western Red Cedar: specify it by name.



On-line cedar school

AN AIA-ACCREDITED EDUCATIONAL RESOURCE

The Western Red Cedar Lumber Association (WRCLA) has launched the WRCLA Architect Cedar School, a program designed to educate architects about the properties and benefits of Western Red Cedar.

Individuals who successfully complete the course are eligible for 7.0 AIA/CES learning unit hours as well as a WRCLA Cedar School Certificate. All active AIA members must successfully complete 18 learning unit hours each year. The course covers seven training and exam modules: Forestry 101, Wood Properties, Wood Manufacturing, Products & Grading, Cedar Marketing & Promotion, Installation of Cedar, Finishing & Maintenance.

“The program was developed by industry experts to provide an in-depth, objective understanding of Western Red Cedar for architects at all levels,” said Peter Lang, general manager of the WRCLA. “Even seasoned professionals will pick up new ideas and information about Western Red Cedar.” The WRCLA Architect Cedar School is available online for rapid and convenient training, as well as a printed version. The program cost is \$95.

To access the architect cedar school site, visit: www.cedar-training.org. For more information about Western Red Cedar and the WRCLA visit www.realcedar.org or call 1-866-778-9096.

WESTERN RED CEDAR LUMBER ASSOCIATION

REAL CEDAR | 1-866-788-9096 | www.realcedar.org

Forest Products - A sound environmental choice

Forests are a global treasure; and a source of beauty, inspiration, recreation and outstanding products. They also play a key role in mitigating climate change by absorbing and storing carbon in trees, soil and biomass. Just as there is no longer any doubt that the climate is changing, there can be no doubt that well-managed forests yield immense environmental and economic benefits.

Healthy growing forests recycle carbon naturally. When biomass is used instead of fossil fuels, it can reduce the build-up of carbon dioxide in the atmosphere. When trees are used for forest products, the carbon often remains stored in the products for decades, or longer.

SOLID WOOD AND CLIMATE CHANGE

Using wood products that store carbon instead of building materials that require more fossil fuel to manufacture can help slow climate change. Trees grow with solar energy, and the little waste generated during processing is often used to meet the energy needs of the mill. At the end of their first life, forest products can be easily reused, recycled or used as a carbon neutral source of energy.

As environmental awareness grows, building professionals are finding wood is an excellent choice for green construction designs, which minimize the use of energy, water and materials, and reduce impacts on human health and the environment. Wood is a high-performance and versatile choice for any new construction or renovation.

LIGHTER FOOTPRINT

Studies show wood products are associated with far less greenhouse gas emissions over their lifetime than building materials such as steel, concrete, aluminum or plastic. For example, substituting a cubic metre of wood for concrete blocks or bricks results in a significant saving of 0.75 to 1 tonne of carbon dioxide.

Numerous international scientific studies demonstrate the environmental benefits of wood. A recent life cycle assessment compared the environmental impacts of homes framed with wood, steel and con-

crete, and found that the production of steel and concrete-framed homes generated 26 per cent and 31 per cent more greenhouse gas emissions, respectively, than their wood-framed counterparts.

The same study found that the production of the steel and concrete homes consumed 17 per cent and 16 per cent more embodied energy and released 14 per cent and 23 per cent more air pollutants than a wood-framed home.

ENERGY EFFICIENT

Wood products require less energy to extract, process and transport, and wood buildings can require less energy to construct and operate over time. If less fossil fuel energy is consumed, fewer greenhouse gases are emitted.

Wood's cellular structure, with lots of tiny air pockets, improves its natural thermal efficiency, making it 400 times better than steel and 10 times better than concrete in resisting the flow of heat. Steel and concrete structures need more insulation to achieve the same thermal performance as wood framing.

In Canada, it has been calculated that the wood industry has one-third the energy intensity of the cement or steel industries per unit of gross domestic product.

DURABLE AND ADAPTABLE

Products that last longer reduce environmental demands. Wood is durable, and wood-frame buildings can be easily adapted to meet new needs and extend their life. After decades or even centuries of use, wood can be re-used in new buildings – and this requires little or no energy.

Wood residue from the production of lumber can be re-manufactured into high-value composite products like medium density fibreboard (MDF), finger-jointed lumber and other wood-hybrid composite lumber. Wood residue is also chipped into mulch for landscaping and agricultural uses.

CONCLUSION

Today more than ever before, we must find ways to reduce the pressure on our planet's environment and finite resources. By choosing products with a light carbon footprint and by reducing waste, we can have a real impact on climate change now, and into the future.

Canada is uniquely positioned to meet the world's demand for products from sustainably managed forests. Our forest industry regenerates harvested areas, it is committed to legal logging, it invites outside scrutiny of its practices and it is committed to carbon neutrality across the value chain.

About the graphic:

The benefits of wood are related to both the energy needed to operate the building and the embodied energy, which relates to the environmental impact of making products and building with them. To understand embodied effects, it's best to view them separately.

This chart compares a typical wood-frame exterior wall with five alternative building systems, in terms of environmental performance in three categories (energy consumption, climate change (greenhouse gas emissions) and air pollution).

The comparison is based on embodied environmental effects – it does not include the environmental impact of operating the building because all of these walls will lead to comparable operating energy use in the building. This allows us to better focus on the actual differences in the wall systems.

Wood is the first bar, set to 100% – in other words, it's the baseline.

The energy consumption, greenhouse gas emissions, and air pollution involved in making an equivalent wall in steel, etc. are shown as greater by various percentages.

So, for example, the insulated concrete forms wall takes twice the energy to manufacture than the wood wall.

Life cycle assessment shows wood is a good choice

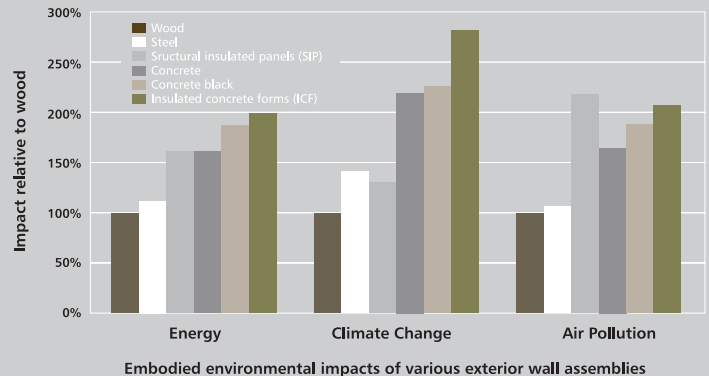

This data was compiled using the Athena EcoCalculator, a free life cycle assessment tool that allows designers to quickly compare environmental profiles of various standard construction assemblies. Version 2.2 was used, with a dataset appropriate for Vancouver, Canada. Results may slightly vary for other regions. This software is available from the Athena Institute, www.athenasmi.ca.

Details on the walls:

1. Concrete block: 8" block, stucco, rigid insulation (R21.67), vapour barrier (vb), gypsum wallboard, paint
2. Concrete: 6" cast in place conc, stucco, rigid ins (R21.15), vb, gyp bd, paint
3. Insulated concrete forms: Ins conc forms (concrete plus Styrofoam, R20.43, stucco, gyp bd, paint
4. Steel: 2x6 steel studs at 16", stucco, 2" rigid ins plus fibreglass batt (R 17.77), vb, gyp, paint
5. Wood: 2x6 wood studs at 16", stucco, fibreglass batt (R16.08), vb, gyp bd, paint
6. Structural insulated panels: Struc ins panels (wood panels plus Styrofoam R 23.24), stucco, vb, gyp bd, paint.



Shannagh-More Outdoor Education Centre

TODD ARCHITECTS

The centre offers schools and community youth groups access to activities such as abseiling, canoeing and orienteering in a garden and woodland setting at the base of the Mourne Mountains, in Newcastle, County Down in Northern Ireland.

The brief included the refurbishment and extension of the existing main building, a large stone clad house built in the 1920s. A stream and dry-stone wall constrained the length of the new addition, but the cross fall of the site offered the opportunity to create a basement storey.

A glazed circulation link connects the existing house to the addition and emphasizes the interface between old and new. It offers views in and out and has become a dramatic visual marker, particularly when illuminated at night.

The ground floor is predominantly glazed so that office and reception spaces are inviting and open. The continuous curtain wall admits ample daylight and constantly reminds users of the spectacular surroundings. The basement level contains ancillary accommodation such as laundry and drying rooms. The upper floor contains washroom facilities and an additional dormitory.

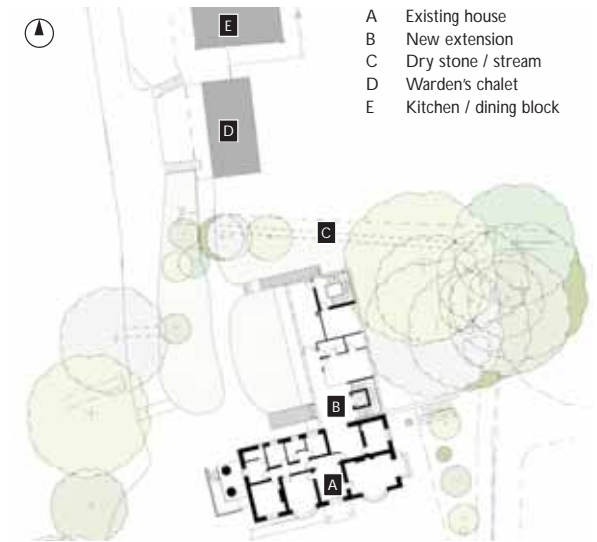

Site plan



A GLAZED CIRCULATION LINK CONNECTS THE EXISTING HOUSE TO THE ADDITION AND EMPHASIZES THE INTERFACE BETWEEN OLD AND NEW. THE GLAZED GROUND FLOOR OFFICE AND RECEPTION ARE INVITING AND OPEN.



Plan, second floor

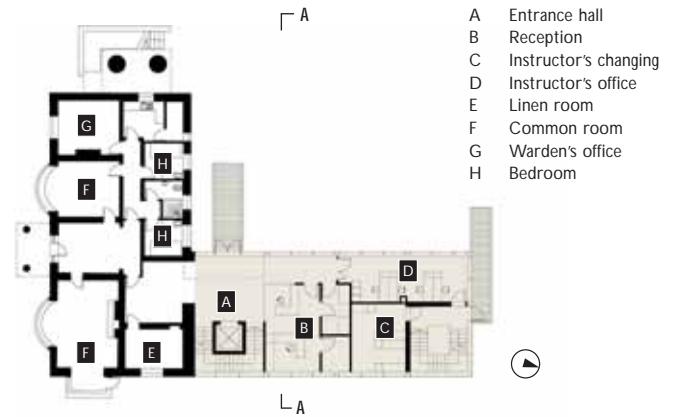

Plan, main floor

In contrast to the ground floor these areas are treated as solid volumes externally, using cedar cladding and simple punched window openings. Mechanical systems are clustered together and exhausted through a penthouse in the sloping zinc roof, further contributing to the simplicity of the wood and glass box.

The cedar cladding adds richness, warmth and colour, but has been left untreated so that it will weather naturally and blend into the woodland setting. The material was chosen for its resistance to moisture and minimal requirement for maintenance.

Cedar Specs

Cedar cladding is natural finish 1x5 boards, No. 2 Clears and Better only, machined to VT9 profile and secret fixed to battens and counter battens using stainless steel annular ring nails.



Section A-A



CLIENT Southern Education & Library Board (SELB), Armagh
ARCHITECT Todd Architects, Belfast
QUANTITY SURVEYOR KS+P, Belfast
STRUCTURAL ENGINEER Mott MacDonald, Belfast
MECHANICAL/ELECTRICAL ENGINEER Taylor & Fegan, Belfast
GENERAL CONTRACTOR Moss Construction (NI) Ltd, Seagahan, Co. Armagh
LUMBER SUPPLIER Vincent Timber, Birmingham
PHOTOS Signals Design & Photography, Bangor

THE UPPER FLOOR IS TREATED AS A SOLID VOLUME EXTERNALLY, USING WESTERN RED CEDAR CLADDING AND SIMPLE PUNCHED WINDOW OPENINGS. INSIDE, WESTERN RED CEDAR LINES THE UNDERSIDE OF THE RECEPTION CEILING AND THE BALUSTRADE TO THE MEZZANINE ABOVE.



West elevation

Horizontal slats allow light to filter through to the corner staircase of the extension. This combines with the horizontal bevel siding on the external walkways to contrast with the flush vertical cladding applied elsewhere. Vertical slats wrap around and enclose an external stair at the side of the existing stone clad house. The cedar has also been used internally to line the underside of the reception ceiling and the balustrade to the mezzanine above.

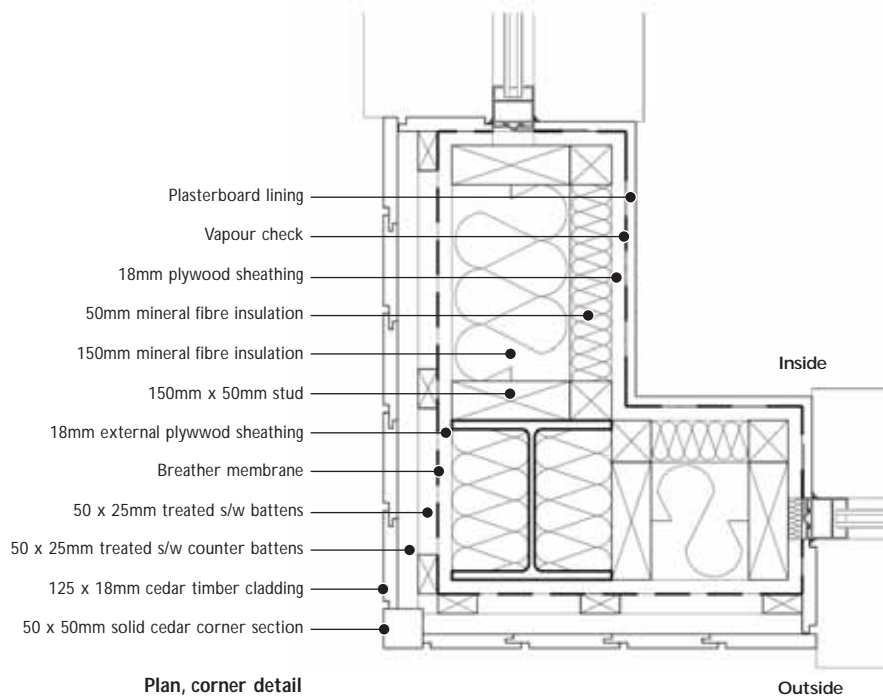

HORIZONTAL WESTERN RED CEDAR BEVEL SIDING CONTRASTS WITH THE FLUSH VERTICAL SIDING. SIDINGS ARE LEFT UNTREATED SO THAT THE PLEASING WEATHERED SILVER-GREY COLOUR OF WESTERN RED CEDAR WILL BLEND NATURALLY INTO THE WOODLAND SETTING.

McBride House

BIRD DE LA COEUR ARCHITECTS

The physical and visual fit of this house into an established garden in Victoria, Australia became a defining influence on the architecture and the choice of materials. The other strong influence came from the vanishing tradition of modest seaside buildings that once lined the coast – now replaced by bloated mansions.

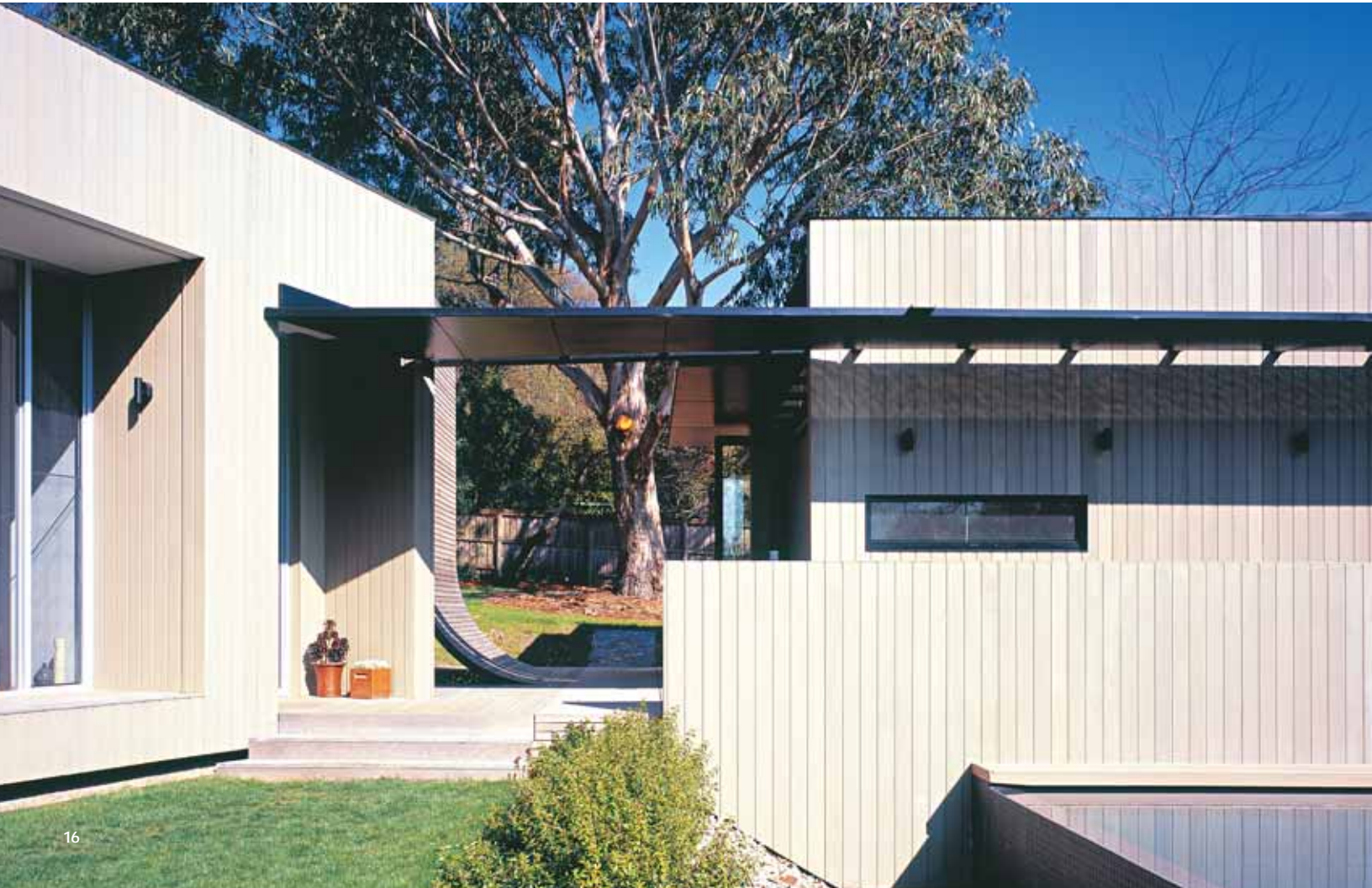

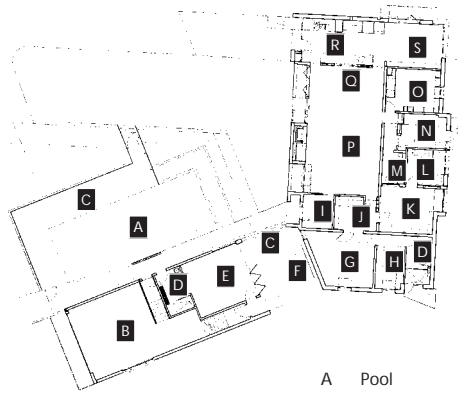

Ground Floor Plan

- A Pool
- B Garage
- C Timber deck

- D Ensuite
- E Summer room
- F Curved timber deck
- G Master bedroom
- H Walk-in-robe
- I Entry
- J Study
- K Bedroom
- L Bath
- M Powder room
- N Laundry
- O Night room
- P Living
- Q Dining
- R Kitchen
- S Family room

The house is sited around two major trees, one of which is a striking blue gum. The tree forms a fulcrum about which the house and outbuilding pivot. The outbuilding, containing garage/workshop, painting studio and a multipurpose 'summer room', creates a covered walkway that is the main access to the house.

The walkway leads past the pool and onto a deck where the full view of the blue gum and main house are revealed. The summer room opens onto the curved 'pacing deck' while the studio above is shielded from the west sun by the balcony formed between two offset cedar walls - complete with seating area and viewing slots.

An analysis of outbuildings reveals them as among the most loved spaces in Australian domestic architecture. The garage, the shed, the studio, the granny flat - what is their appeal? Perhaps it is the elemental nature of the shelter they provide - a building reduced to wall and roof. Here, the timber out building is moved to the front of the site, conceding the higher ground to the main house, which benefits from the cooling effect of the southerly breezes.



THE SECOND-STOREY STUDIO IS SHIELDED FROM THE WEST SUN BY THE BALCONY FORMED BETWEEN TWO OFFSET WESTERN RED CEDAR WALLS - COMPLETE WITH SEATING AREA AND VIEWING SLOTS.

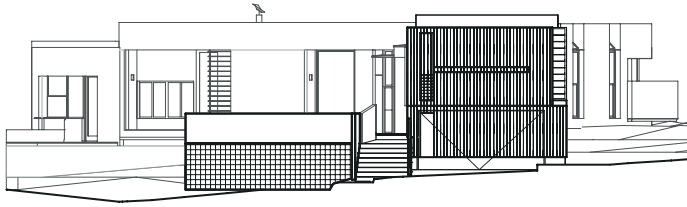

Front Elevation

Cedar was chosen for its unique combination of attributes. Its 'lightness' suited the reference to outbuildings and to the previous generation of modest coastal cottages. Its stability and fine grain helped achieve the sharp graphic outline of the studio wing and the refined face of the main house, while providing a contrast to the coarser grain of the spotted gum. A renewable resource, its high resistance to decay, fungal and insect damage, as well as its dimensional stability were critical to the project, which is located in a marine environment and termite zone.

THE OUTBUILDING, CONTAINING GARAGE, STUDIO AND A 'SUMMER ROOM', CREATES A COVERED WALKWAY TO THE HOUSE. THE SUMMER ROOM OPENS ONTO THE CURVED 'PACING DECK.' THE NATURAL STABILITY AND DECAY RESISTANCE OF WESTERN RED CEDAR SUITS THE MARINE ENVIRONMENT AND TERMITE ZONE.

Cedar Specs

Cladding: Class 2 135 x18mm vertical shiplap Western Red Cedar, fixed with silicon bronze nails and coated with 2 coats of water-based finish.



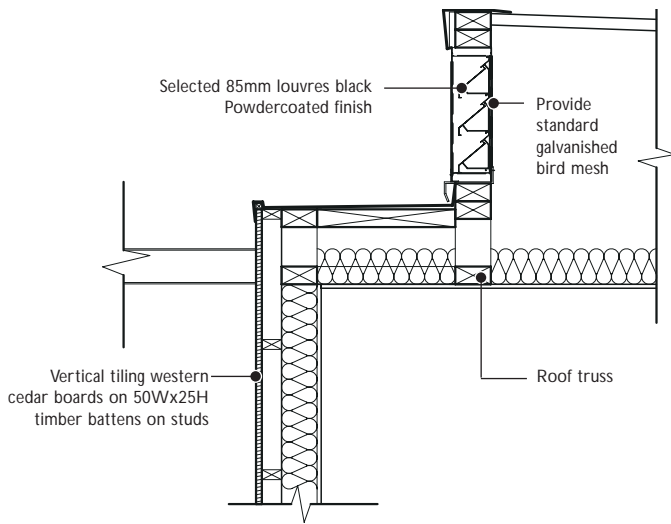

Section, roof

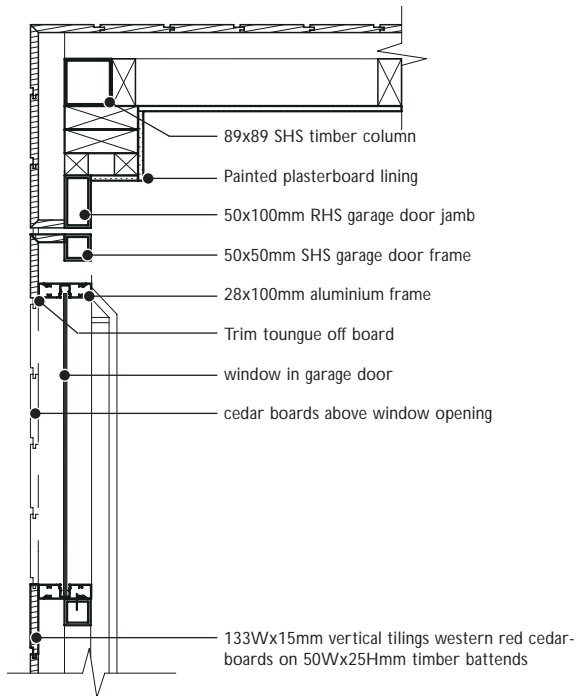

Plan, corner detail



CLIENT Graham and Rhona McBride
 ARCHITECT Bird de la Coeur Architects, VIC Australia
 LANDSCAPE ARCHITECT Rush/Wright, VIC Australia
 STRUCTURAL ENGINEER Multiple Design Engineering Consultancy
 BUILDER Melford Construction P/L, Balnarring VIC Australia
 LUMBER SUPPLIER Tilling Timber, Kilsyth VIC Australia
 PHOTOS Shannon McGrath



CLIENT The University of British Columbia
ARCHITECT Larry McFarland Architects Ltd.
STRUCTURAL ENGINEERS Fast + Epp Partners
MECHANICAL ENGINEERS Stantec Consulting Ltd.
ELECTRICAL ENGINEERS Cobalt Engineering
SUPERSTRUCTURE CONTRACTOR Kindred
Construction Ltd.
FLOATING STRUCTURE CONTRACTOR
International marine Flotation Systems



John M.S. Lecky UBC Boathouse

LARRY MCFARLAND ARCHITECTS LTD.

Located on the Fraser River in Richmond, BC and accessed through a riverfront park, the boathouse serves the University of British Columbia and St. George's College rowing teams. It hosts community rowing and dragon boating as well as regattas and other public events.

The design team's objective was to find an architectural expression that would reflect the simplicity and harmony of rowing, and enable the building to sit comfortably in its natural setting while celebrating the storied tradition of the UBC rowing club. Most critical was the decision to create a floating facility, a solution that brings occupants close to the water, solves the problem of poor soil conditions, and dramatically enhances the site experience, creating a dynamic relationship between the building and its surroundings. This decision also made it possible to prefabricate the building off site, and tow it into place, greatly reducing site disturbance and the physical impact on the park. The two rectangular volumes of the boathouse sit at an angle to the riverbank, either side of the access ramp. The carefully devised circulation pattern greatly increases the efficiency of the plan, allowing the facility to support a volume and diversity of rowing programs that rivals much larger facilities.

Externally, the shallow curve of the roof line is carried through into exterior cedar screens to the east and west that soften the silhouette and cast dancing shadows on the building skin. The

THE DECISION TO HAVE THE BOATHOUSE FLOAT MEANT IT COULD BE PREFABRICATED OFF SITE, AND TOWED INTO PLACE, THUS GREATLY REDUCING SITE DISTURBANCE AND THE PHYSICAL IMPACT ON THE ADJACENT PARK.



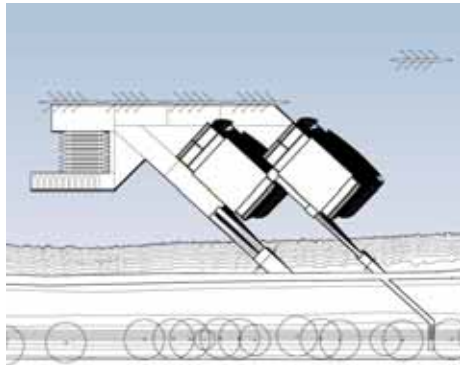

Site plan



cedar screens help to shade the west face of the building from the afternoon sun and define the edges of the viewing decks. On the east face, the screens provide some protection from the prevailing winds and a 'veil' for the window facing directly into the public park.

The cedar creates visual warmth, contrasting with the corrugated metal cladding, anodized aluminum window mullions, and polycarbonate glazing, demonstrating the positive effect that even a small quantity of wood can have on the tactile and sculptural quality of a building.



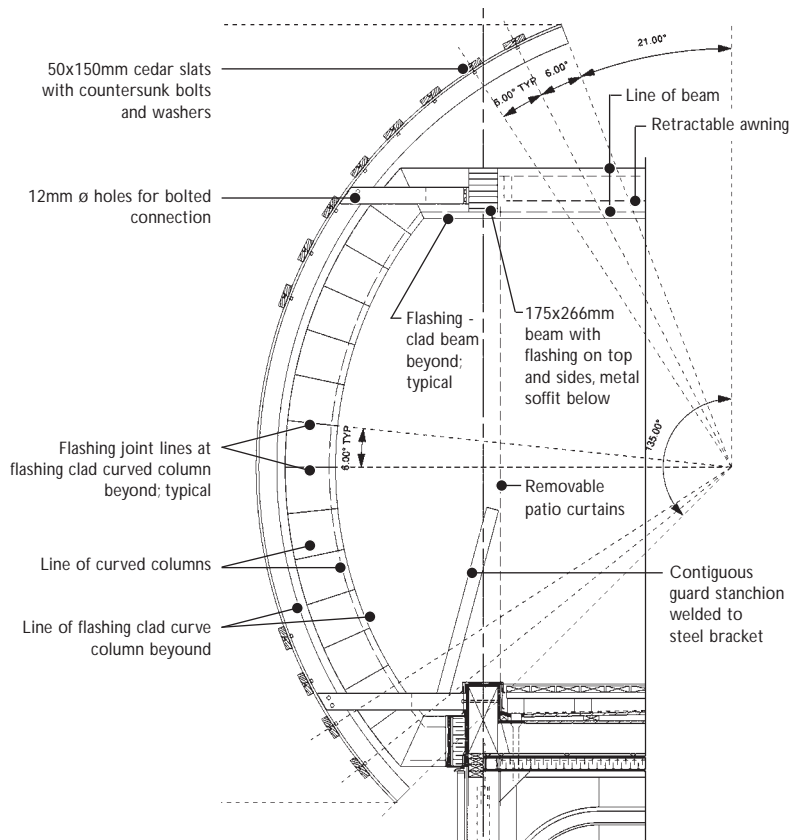

Section, cedar screen

THE SHALLOW CURVE OF THE ROOF LINE CARRIES THROUGH INTO EXTERIOR CEDAR SCREENS THAT SOFTEN THE SILHOUETTE AND CAST DANCING SHADOWS ON THE BUILDING SKIN. THE PROJECT DEMONSTRATES THE POSITIVE EFFECT THAT EVEN A SMALL QUANTITY OF WESTERN RED CEDAR CAN HAVE ON THE TACTILE AND SCULPTURAL QUALITY OF A BUILDING.



Cedar Specs

The cedar screens are made up of 2x6 sanded edge grain custom clear all-heart Western Red Cedar slats, and are fastened with countersunk hot-dipped galvanized bolts and washers to curved hot-dipped galvanized steel brackets. The cedar is finished with a natural appearance UV resistant stain.



Linden Hills weeHouse®

ALCHEMY ARCHITECTS

Counter to the prevalent 'bigger is better' trend in US housing, the weeHouse prefabricated modular housing system is a study in economy and efficiency. Designed from the inside out, the program of a weeHouse home is divided into compatible functional groupings that can be organized within prefabricated boxes of standard width.

Typically, one box may contain bedroom and bathroom spaces, kitchen and dining areas or living spaces. Depending on the size and complexity of the program, a house might comprise one, two, three or four boxes arranged side by side or stacked.

By grouping the program elements strategically, the lengths of the four boxes used in the Linden Hills weeHouse in Minneapolis MN are of varying length, and when assembled create overhangs, cantilevers and roof decks that break up the scale of the building mass. This articulation also begins to create a dialog between the public and private realm within a typical urban lot.

With four bedrooms and three bathrooms, the Linden Hills house has an area of 2200sf above ground, a 700sf finished basement and a two-car tuck-under garage. The four boxes were transported to site by truck and lifted into place with a crane, enabling the whole house to be completed on-site within eight weeks, greatly reducing both the time and costs associated with typical high-end custom architecture. Factory prefabrication has been shown to improve quality control and speed up construction by eliminating the vagaries of weather and allowing the foundation to be prepared while the modular units are being fabricated.

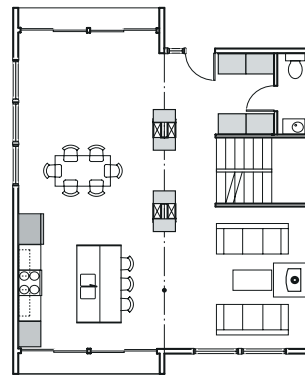

Plan, main floor

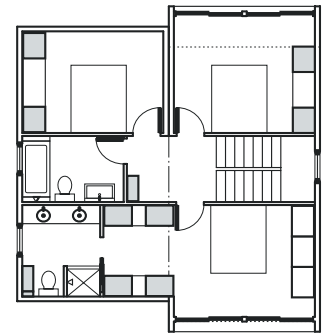

Plan, second floor

CLIENT Mr. Brian Oeschger
ARCHITECT Alchemy, LLC
PROJECT DESIGNER/MANAGER Scott Ervin
STRUCTURAL ENGINEERS Stroh Engineering Services
MODULE FABRICATION Norse Building Systems

Cedar Specs

Western Red Cedar cladding is 1x6 T&G, Grade A and Better, toe-nailed through the tongue with galvanized nails and coated with a clear finish.

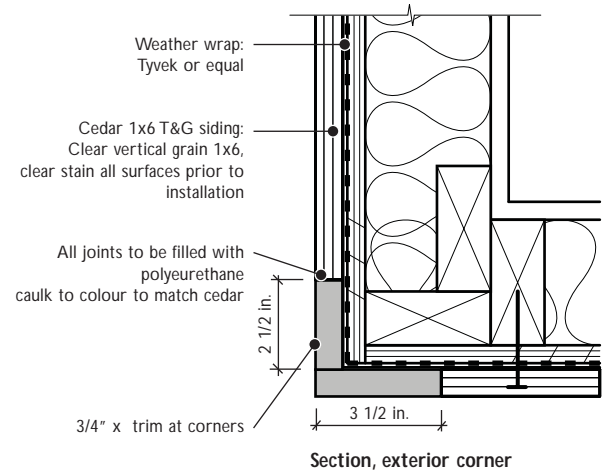

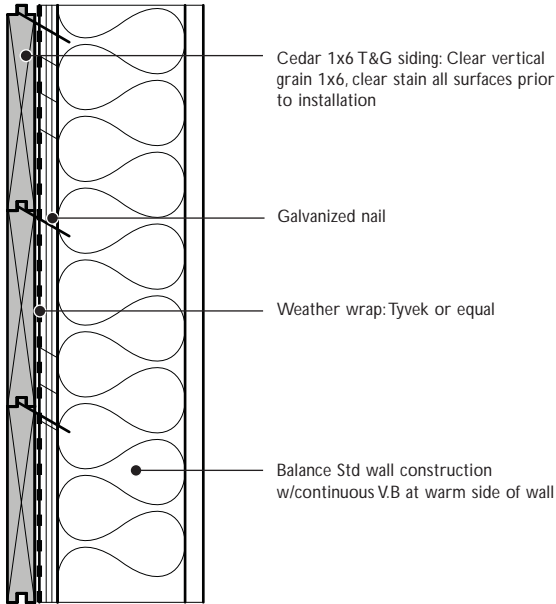

Section, wall

Using different types of low maintenance siding, painted cement board, and clear tongue and groove cedar, the Linden Hills house showcases and celebrates the modular nature of the house. Using a classic material like wood siding helps this modern contemporary home to blend into the traditional residential scale and fabric of the neighbourhood.

Creative design and attention to detail has resulted in a spacious and elegant home that challenges the “monster house” phenomenon head-on.

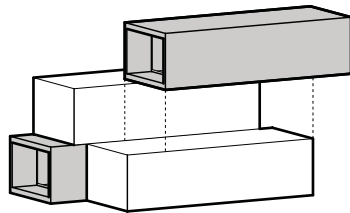

THE FOUR PREFABRICATED MODULES BOXES WERE LIFTED INTO PLACE WITH A CRANE, ENABLING THE WHOLE HOUSE TO BE COMPLETED ON-SITE WITHIN EIGHT WEEKS, GREATLY REDUCING BOTH THE TIME AND COSTS. WESTERN RED CEDAR SIDING HELPS THE CONTEMPORARY HOME BLEND INTO THE TRADITIONAL NEIGHBOURHOOD.



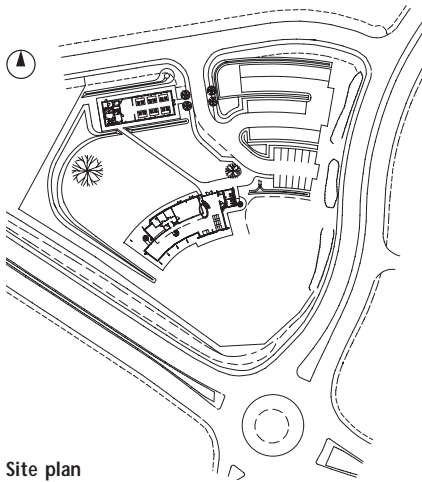

Site plan

CLIENT VELUX
ARCHITECT White Design
STRUCTURAL ENGINEER Buro Happold
Consulting Engineers
MECHANICAL/ELECTRICAL ENGINEER
Halcrow Gilbert (Swindon)
GENERAL CONTRACTOR Willmott Dixon
TIMBER CONTRACTOR Lilleheden (Denmark)

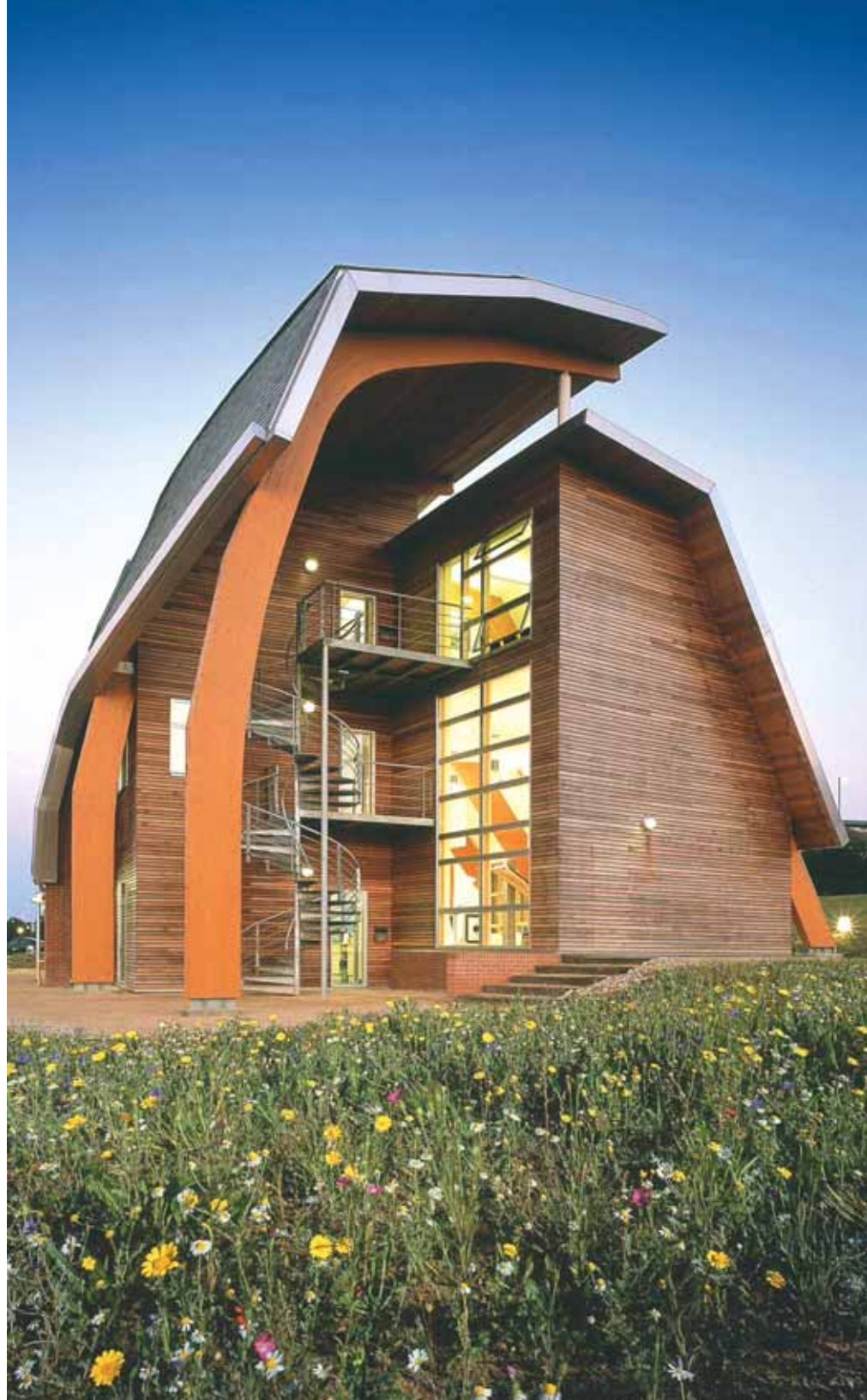

Velux Offices

WHITE DESIGN ASSOCIATES LTD

When the Danish window company VELUX commissioned a building to house its sales and training team in Kettering, England it aimed to create an environment that fully exploited the potential of its products to contribute to the green design agenda. The company has built a worldwide reputation on its sophisticated roof window that floods a room with natural light and offers easy control of natural ventilation – two fundamental elements of sustainable architecture.

The ingenious cross section of the four-storey building that almost eliminates vertical walls, offers many opportunities to integrate roof windows while providing for excellent natural lighting and ventilation. The gentle curve of the plan and the clever use of double, sometimes triple height spaces create a dramatic interior bathed in light that evokes images of both metropolitan lofts and medieval barns. The organic form that seems to grow directly from the gently sloping site makes a striking contrast with the disparate sheds that surround the site in the distinctly workaday setting of a business park on the outskirts of Kettering, a small city located almost in the centre of England.

The strength of the building lies in its limited palette of materials. Inside the great curving glulam structural ribs, which recall the ancient English tradition of cruck construction, and the warm timber floors contrast with the white painted plaster of walls and ceilings. The exterior combines horizontal western red cedar boarding, cedar shingles and slate.



THE CURVED ORGANIC FORM AND WARMTH OF WESTERN RED CEDAR SIDING MAKE A STRIKING CONTRAST WITH THE WORKADAY SETTING OF THE NEARBY BUSINESS PARK.

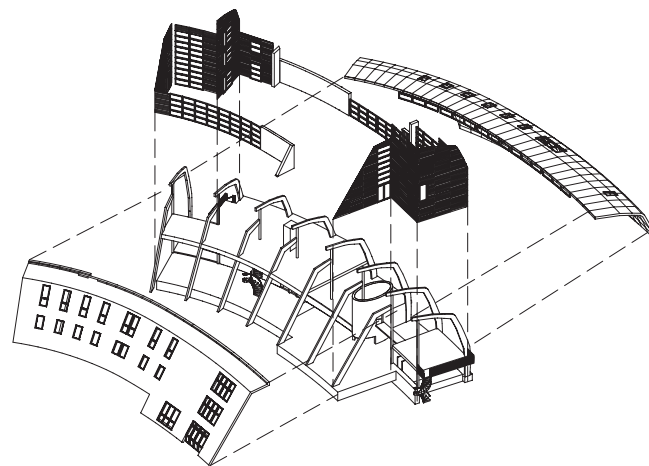

Axonometric view

The subtle variation of colouring and the warm texture of the cedar speak of green aspirations in design at the same time bringing to mind a suitably domestic image for the promotion of the company's products. Timber in its many forms is increasingly seen as having the potential to make a contribution to the greening of design and construction in the UK. The natural weather resistance and durability of cedar were key considerations for the designers when choosing the cladding for this very visible project.

INSIDE, THE GREAT CURVING GLULAM STRUCTURAL RIBS RECALL THE ANCIENT ENGLISH TRADITION OF CRUCK CONSTRUCTION. THE EXTERIOR COMBINES SLATE WITH WESTERN RED CEDAR HORIZONTAL BOARDS AND SHINGLES, CHOSEN FOR ITS NATURAL WEATHER RESISTANCE.

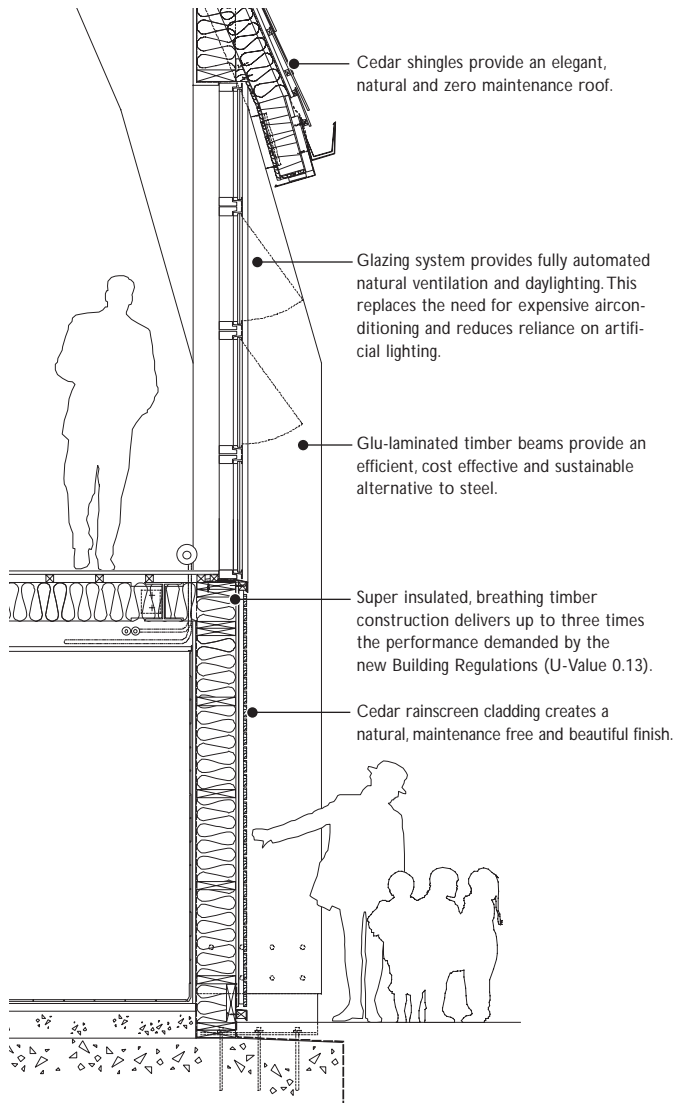

Section, Wall



Cedar Specs

Western Red Cedar cladding is natural finish 1x5 boards, No. 2 clears and better only, machined to VT9 profile and secret fixed to battens using stainless steel annular ring nails.



Houses at Jacks Point

SHANAHAN ARCHITECTS LTD.

Jacks Point is a new township being built on the shores of Lake Wakatipu in New Zealand's Southern Lakes region. Close to the tourist and recreational centre of Queenstown, Jacks Point provides resort style living and a holiday environment centered around its 18 hole golf course.

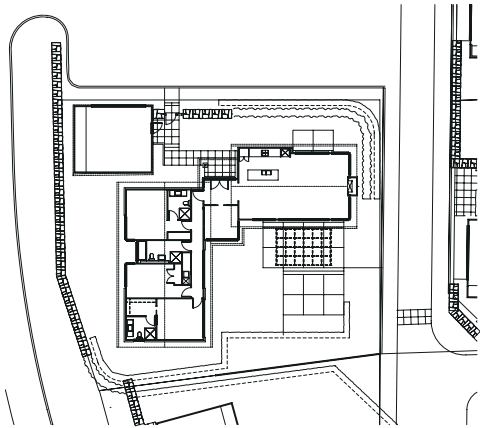

Site plan

The land is situated in a glaciated valley at the foot of The Remarkables range with views to the spectacular mountains and valleys that border the lake.

Design guidelines based on simple forms, natural materials, muted colours and indigenous landscaping aim to create a place that blends into its environment. The houses at Jacks Point have been designed to appeal to a wide range of holiday makers as well as permanent residents. Each house uses living, sleeping and garage modules to form a protected and sunny courtyard where residents can enjoy the beauty of the natural surroundings.

Western Red Cedar used for wall cladding is complemented by areas of stucco painted in earthy tones, while the predominant cedar roof shakes are complemented by a smaller number of roofs finished in profiled copper.

Bevel back profile weatherboards and wide cedar facings around the aluminum windows give a traditional texture to the



DESIGN GUIDELINES BASED ON SIMPLE FORMS, NATURAL MATERIALS, MUTED COLOURS AND INDIGENOUS LANDSCAPING BLEND THE HOUSES INTO THE ENVIRONMENT.

EACH HOUSE USES LIVING, SLEEPING AND GARAGE MODULES TO FORM A PROTECTED AND SUNNY COURTYARD WHERE RESIDENTS CAN ENJOY THE BEAUTY OF THE NATURAL SURROUNDINGS.



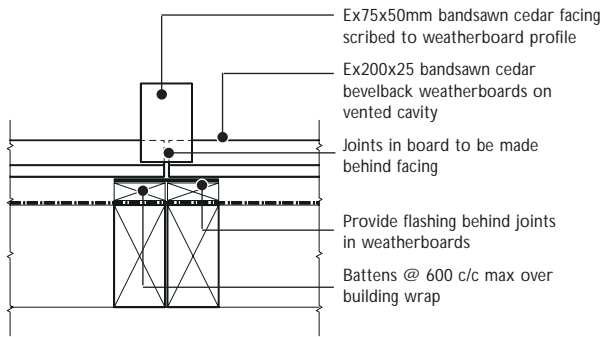

Plan, facing detail

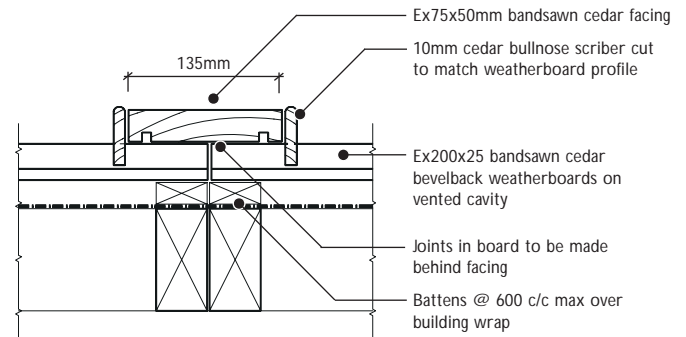

Plan, facing detail



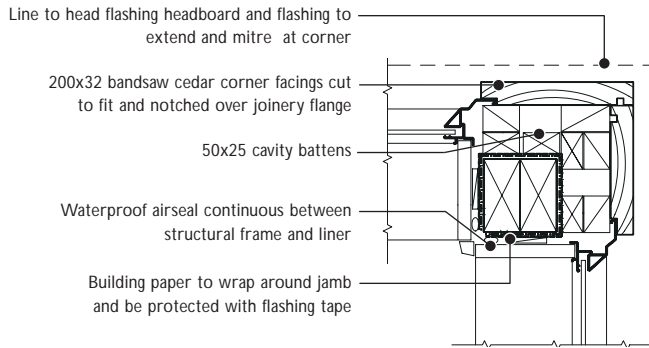

Plan, jamb detail

cladding. Corner boxing frames the edges of the buildings and weatherboards are installed in standard lengths with cover boards used to conceal the joints. The roofs have wide overhangs, cedar soffits and their double barge and eaves facings add to the feeling of depth and solidity.

The local climate is demanding with hot summers, cold winters and wind blown rain attacking the buildings in southerly storms. The layered approach to the detailing provides a robust and proven weatherproof skin as well as creating depth and interest to the façade.

The extensive use of Western Red Cedar ensures that the houses sit easily within the natural environment while the traditional detailing with multiple layers of board reflects the craftsmanship of the builders and the welcome touch of the human hand.



BEVEL BACK PROFILE WESTERN RED CEDAR WEATHERBOARDS AND WIDE FACINGS AROUND THE ALUMINUM WINDOWS GIVE A TRADITIONAL TEXTURE TO THE CLADDING.

THE LAYERED APPROACH TO THE DETAILING PROVIDES A ROBUST AND PROVEN WEATHERPROOF SKIN AS WELL AS CREATING DEPTH AND INTEREST TO THE FAÇADE.



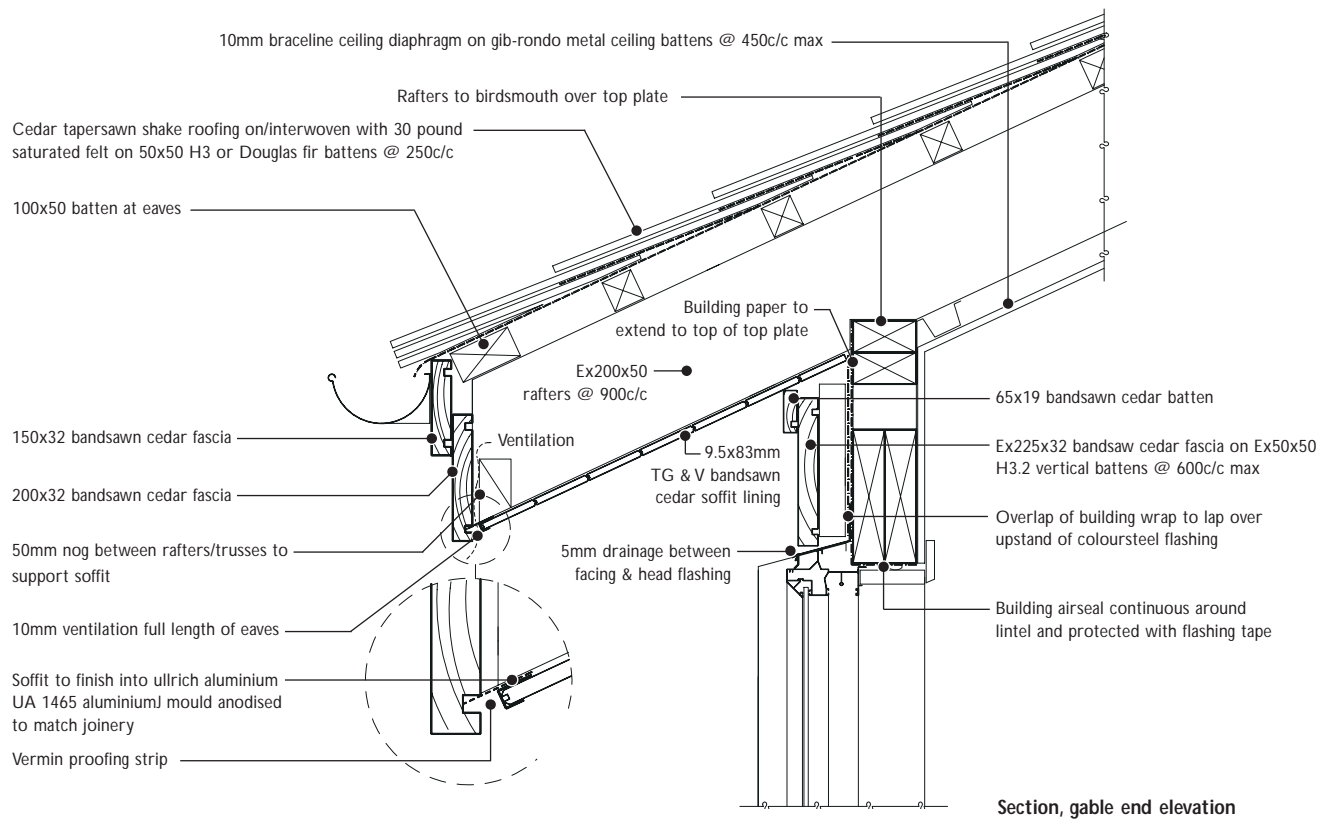

ARCHITECT Shanahan Architects Ltd.
 CONTRACTOR Fletcher Residential
 PHOTOS David Comer

THE TRADITIONAL DETAILING WITH MULTIPLE LAYERS OF WESTERN RED CEDAR BOARD REFLECTS THE CRAFTSMANSHIP OF THE BUILDERS AND THE WELCOME TOUCH OF THE HUMAN HAND.

Cedar Specs

The cedar siding is 7/8" x 8" Grade 2 Clear & Better bevel back profile boards with a band sawn finish, fastened with rosé head annular groove silicon bronze nails.



Tseshahat First Nation Tribal Multiplex

LUBOR TRUBKA ASSOCIATES ARCHITECTS

Among the most important cultural values of West Coast First Nations is their respect for and attachment to nature, as well as their affinity to wood and its multiple applications in their daily lives. The important design ambition for this project was to embody these values in the creation of new accommodation for the Tseshahat First Nation in Port Alberni, BC, Canada from which they could run their various businesses, and fulfill community, health, cultural and social functions.



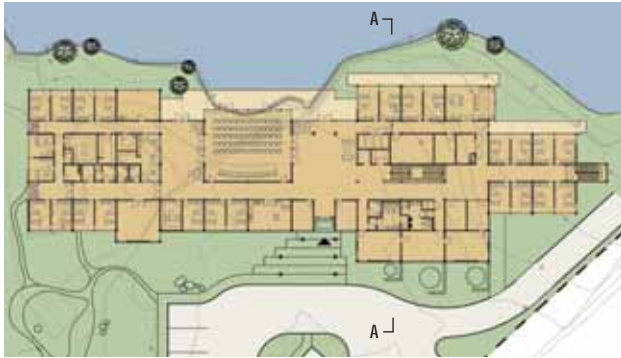

Site plan



The natural yet challenging character of the site, a large granite bluff above the salmon-bearing Somass River, offered a unique opportunity for an environmentally responsible solution. Instead of disturbing the site with rock blasting, levelling and massive excavations, the building follows the contours of the rocky bluff as an elevated wood structure that appears to be floating and is at times cantilevered above the river's edge. To maintain the symbiotic relationship between the internal spaces and the natural exterior, and to take advantage of natural light, the sun's rays are welcomed into the building on their daily path.

Located at the north tip of Alberni Inlet off the West Coast of Vancouver Island, the site is subjected to tidal fluctuations of up to 15ft. and is within the highest seismic risk zone. The structure is a combination of open-framed post-and-beam infilled with glazing and strategically placed sheer walls, utilizing a multitude of engineered wood products and a variety of natural lumber products harvested and milled by Tseshaht from their own forest reserves.

NEARLY EVERY ELEMENT OF THE STRUCTURE IS EXPOSED AS AN ARCHITECTURAL FEATURE AND WAS PRE-MANUFACTURED PREDOMINANTLY BY BAND MEMBERS. WESTERN RED CEDAR WAS USED ON THE EXTERIOR SOFFIT AND TRELLIS, AND ON SELECTED INTERIOR WALLS.



CLIENT Tseshaht First Nation
 ARCHITECT Lubor Trubka Associates Architects
 STRUCTURAL ENGINEER CWMM Consulting Engineers Ltd.
 MECHANICAL/ELECTRICAL ENGINEER MCW Consultants Ltd.
 CIVIL ENGINEER Kerr Wood Leidal Associates Ltd.
 GEOTECHNICAL ENGINEER McQuarrie Geotechnical
 Consultants Ltd.
 GENERAL CONTRACTOR BB Builders Ltd.

Cedar Specs

All of the cedar was logged by client specifically for this project and the quality was exceptional – near to clear grain.

Exterior

Building soffit: Clad with 1x6 square edge Western Red Cedar, spaced 1/4" for ventilation.

Trellis: Made from 2x5-1/2 clear and almost vertical grain boards.

All exterior wood pre-finished on site with two coats of Sikkens Cetol 1 and one coat of Cetol 23 PLUS.

Interior

Approximately 2,000sf of interior wall surface clad with 1x6 cedar, pre-finished with water-based Target Emtech 9300 in clear satin.

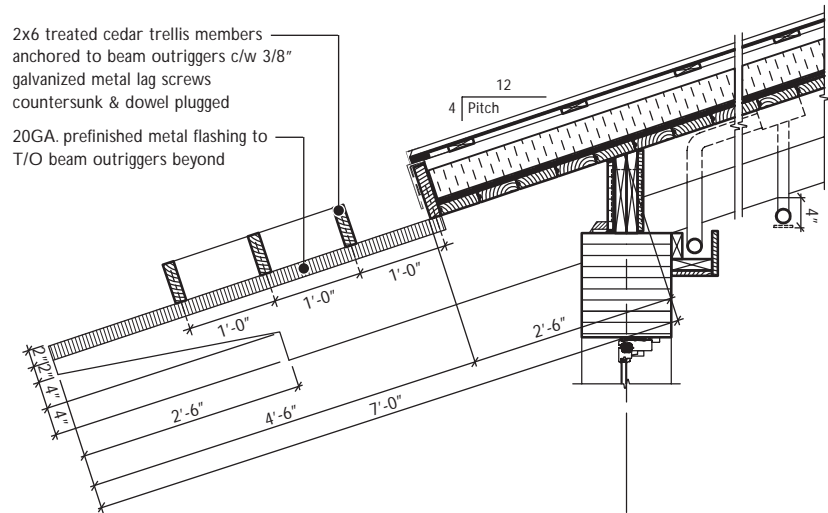

Plan, Detail of the Western Red Cedar trellis on sloped roof



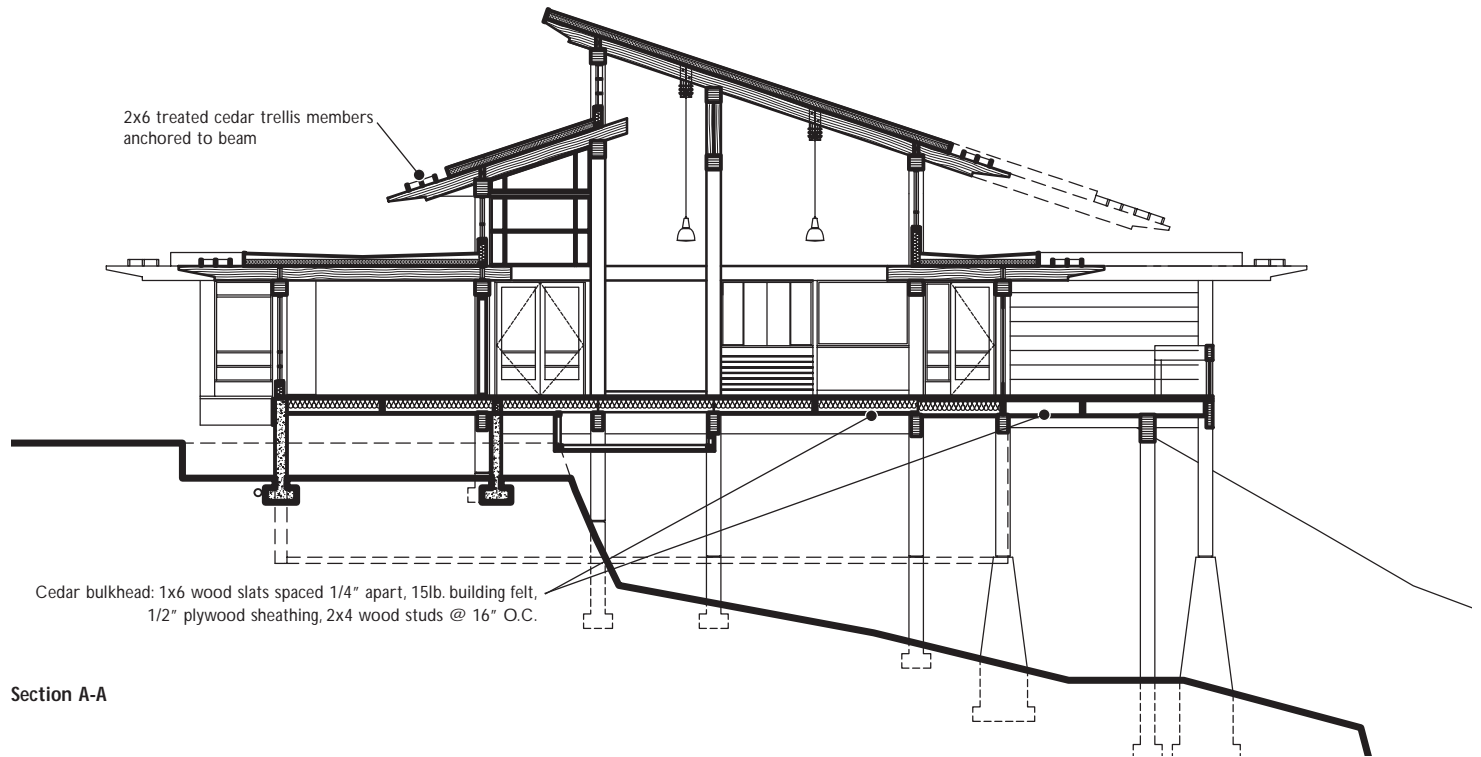

The design concept, that exposes every element of the structure as an architectural feature, required precision pre-manufacturing of each element. This was carried out very successfully on site by crews made up predominantly of Band members. It also presented considerable challenge to conceal all mechanical and electrical distribution systems and position large equipment without detracting from the integrity of the architecture or structure.

Cedar was chosen for the extensive exposed soffit of the building, as well as for the multiple trellis elements that encompass the perimeter of the roof.





Grand Teton Discovery and Visitor Centre

BOHLIN CYWINSKI JACKSON

The Grand Teton Discovery and Visitor Center is sited between a sagebrush meadow and a riparian forest along the Snake River in Moose, Wyoming. Visitors are drawn into a courtyard that provides a calm and intimate place in the vast landscape. A colonnade of Douglas fir logs surrounds the courtyard and provides protection from the summer sun and heavy winter snowfall. The roof tilts upward and away from the courtyard, its jagged edges celebrating the peaks of the Teton Range beyond.

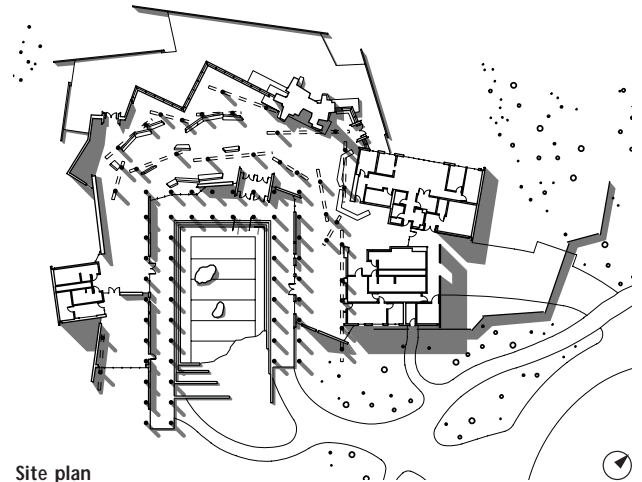

Site plan

The building evokes historic National Park architecture and is designed for durability in an alpine climate. The board-formed concrete walls and wainscot, Douglas Fir columns and Western Red Cedar siding will weather naturally and complement the colours and patterns of the landscape. At the courtyard, the siding is protected by deep overhangs and will retain its rich, warm colour to welcome visitors to the facility. The clear cedar shiplap siding is layered in a variety of widths and thicknesses, with patterns of exposed galvanized fasteners to express the means of construction.

The focal point of the building is a large multipurpose gathering hall with an information desk, interpretive exhibits, casual seating and a magnificent view of the Teton Range. Douglas Fir log frames support engineered wood beams that radiate from the center of the plan and cantilever past the viewing windows. All structural wood elements are FSC certified, in keeping with the Park's mission of sustainability.



A large fireplace acts as the symbolic and physical focal point of the room. A bookstore, art gallery and classroom are placed adjacent to the gathering space, and additional program elements are arranged as discrete wooden boxes containing the NPS offices, visitor amenities and support spaces. Douglas Fir veneer plywood and clear heart Western Red Cedar are used as wall panels and casework throughout the visitor center.

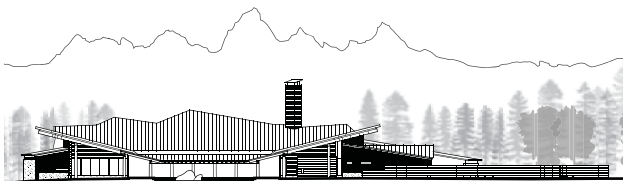

Southeast elevation

The new facility pays homage to the strong tradition of rustic architecture in the national parks while remaining fully modern in its design, execution and interpretive mission.



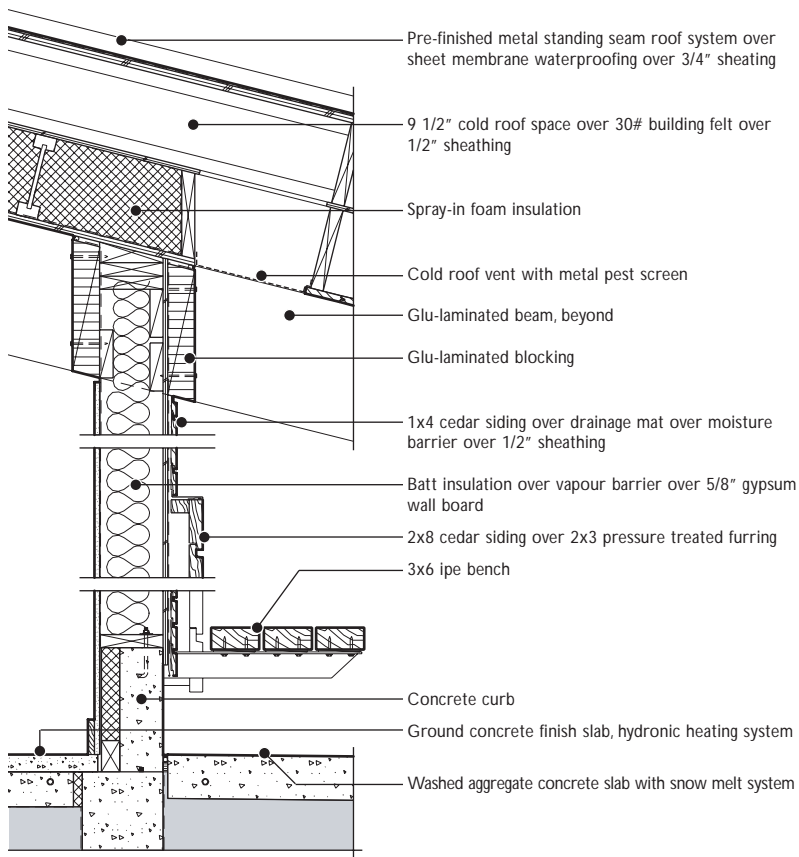

Section, roof and wall



EXPOSED GALVANIZED FASTENERS EXPRESS THE MEANS OF CONSTRUCTION. DOUGLAS FIR VENEER PLYWOOD AND CLEAR HEART WESTERN RED CEDAR ARE USED AS WALL PANELS AND CASEWORK THROUGHOUT THE VISITOR CENTRE.

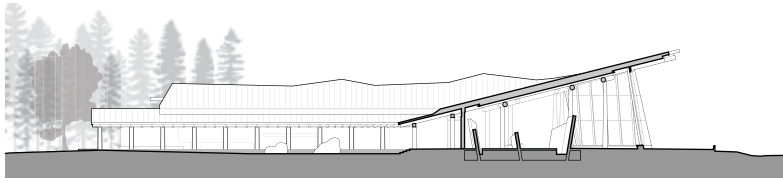

Building section



OWNER National Park Service, Grand Teton National Park Foundation,
Grand Teton Association

ARCHITECT Bohlin Cywinski Jackson

STRUCTURAL ENGINEER Beaudette Consulting Engineers, Inc.

MECHANICAL/ELECTRICAL ENGINEER Gordon Prill Drapes, Inc

LANDSCAPE ARCHITECT Swift and Company

INTERPRETIVE DESIGN Ralph Applebaum Associates

ACOUSTICAL ENGINEER The Green Bush Group

LIGHTING DESIGN Renfro Design Group, Inc.

COST ESTIMATING Davis Langdon

CIVIL ENGINEER/SURVEYOR Nelson Engineering

SNOW COUNTRY DESIGN Ian Mackinlay Architecture

GENERAL CONTRACTOR Intermountain Construction Inc.

WRC LUMBER SUPPLIER BMC West Building materials

PHOTOS Nic Lehoux, Peter Mauss/ESTO, Edward Riddell,
Henry Holdsworth

Cedar Specs

Exterior

Clear Heart Western Red Cedar siding, shiplap profile in
3 sizes: 1x4, 2x8, 2x12

Interior

Information desk clad with a combination of 2x8 and 1x4 Western
Red Cedar siding. Also, at various locations the Western Red
Cedar clad exterior walls continue from the
outside to the interior.

Fastening

2x8 and 2x12 fastened with 3/8-in. galvanized hex-head lag screws.
1x4s fastened with galvanized finish nails



DEEP OVERHANGS AT THE COURTYARD WILL PROTECT THE RICH, WARM COLOUR OF THE WESTERN RED CEDAR SIDING. THE CLEAR WESTERN RED CEDAR SHIPLAP SIDING IS LAYERED IN A VARIETY OF WIDTHS AND THICKNESSES.



CLIENT Geoff and Gwynne Battersby
ARCHITECT Battersby Howat
STRUCTURAL ENGINEER Bevan-Pritchard Man Associates Ltd.
ELECTRICAL ENGINEER Canyon Industrial Electrical Service
PRIME CONTRACTOR K.G. Contracting
WESTERN RED CEDAR SUPPLIER Sunbury Cedar

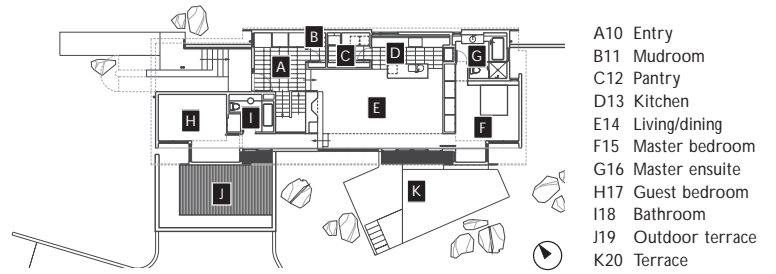

Battersby House

BATTERSBY HOWAT

Vancouver-based architect David Battersby designed this modest retirement home for his parents in the small town of Revelstoke in the rugged southern interior of British Columbia.

The house sits amid indigenous plants, on a rocky and gently sloping site above the banks of the Columbia River. The deceptively simple design cleverly responds to the harsh climate and, at the same time, takes advantage of the spectacular views that include both the turbulent waters of the river and the imposing bulk of nearby Mount McKenzie.

At just 1650sf, plus a finished basement, the plan of the two-bedroom house is both economical and efficient. An elongated rectangle extends east to west across the site, opening the long south elevation to light and views, and limiting the more problematic solar exposure on the east and west sides. In contrast, the north elevation has limited glazing to the less frequently occupied spaces.

The basement includes an entry from the garage and a family room, while the main floor places the living, dining and galley kitchen areas neatly and somewhat unusually between the master and guest bedrooms.

The form of the building and the palette of materials are also simple and robust. A standing seam metal shed roof slopes from

THE TWO-BEDROOM HOUSE HAS AN ECONOMICAL AND EFFICIENT PLAN CONSISTING OF AN ELONGATED RECTANGLE IN WHICH THE LONG SOUTH ELEVATION RECEIVES FULL LIGHT AND VIEWS.



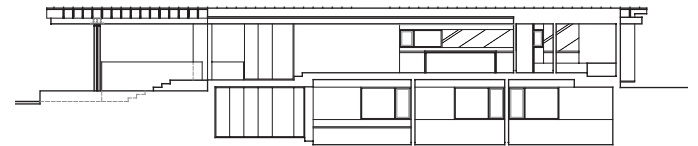

Building section

THE COOL APPEARANCE OF THE METAL CLADDING CONTRASTS WITH THE VISUAL WARMTH OF THE HORIZONTAL WESTERN RED CEDAR SIDING USED IN THE MORE SHELTERED AREAS WHERE THE OCCUPANTS ENGAGE THE BUILDING.

south to north, diverting Revelstoke's legendary snowfalls to the rear of the building, preserving views from the south windows, and protecting the potentially unstable riverbank below the house.

In the most exposed areas of the building, the metal roof folds over the eaves to become vertical siding on the canted exterior walls. The cool appearance of the metal cladding contrasts with the visual warmth of the horizontal Western Red Cedar siding that was chosen to line the more sheltered areas where the occupants engage the building.

In an area on the cusp of massive recreational development, the clarity and simplicity of this project suggests a pragmatic and contemporary alternative to the prevailing chalet style historicism of most alpine resort developments.

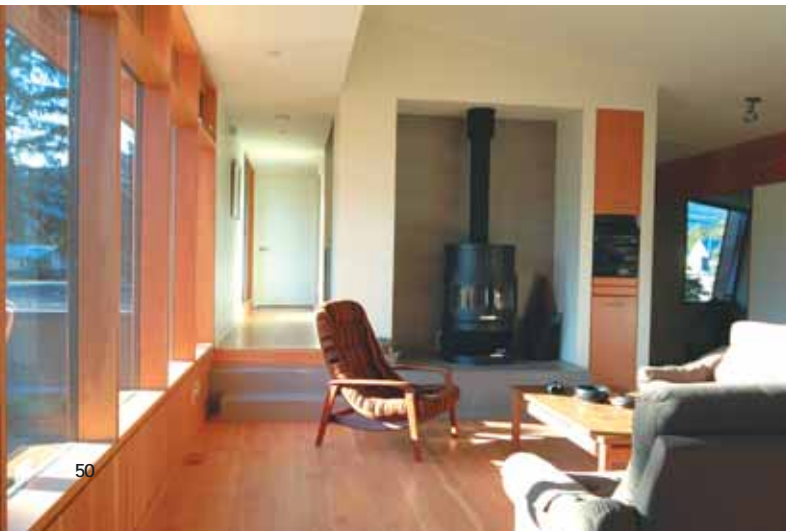

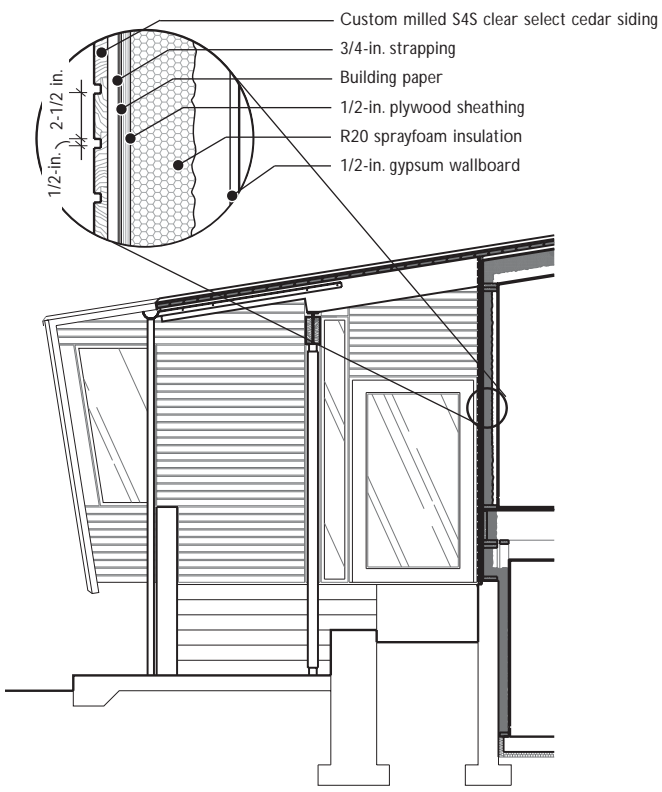

Detail, wall

Cedar Specs

Horizontal 2x4 tongue and groove siding, secret fixed with galvanized nails through tongue, and clear finished.



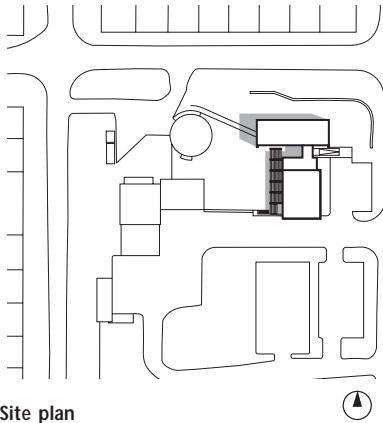

Site plan

Operations Centre

BUSBY PERKINS+WILL ARCHITECTS

This 6000sf facility, houses the public works department for the City of White Rock in British Columbia's lower mainland. The project comprises two linked buildings, one a single-storey structure housing administrative offices, the other a two-storey structure containing service facilities for municipal operations field crews.

These two pavilions are separated by the main entrance which takes the form of a recessed glazed line, beyond which is a planted courtyard visible as one approaches the building. This project was the first new building in Canada to receive a LEED (Leadership in Energy and Environmental Design) Gold rating from the US Green building Council.

CLIENT City of White Rock, Operations Centre
 ARCHITECT Busby+Associates Architects Ltd: V. Berg, P. Busby,
 D. Dove, S. Edwards, R. Maas, A. Malczyk, A. Slawinski, K. Wardle
 STRUCTURAL ENGINEERS Fast + Epp
 ELECTRICAL ENGINEERS Fligel Lewandowzki
 MECHANICAL ENGINEERS Keen Engineering
 GENERAL CONTRACTOR KDS Construction
 LANDSCAPE Wendy Grandin
 INTERIORS Busby + Associates Architects
 IAQ CONSULTANT Pacific Environmental Consulting Services



THE TWO PAVILIONS ARE CONNECTED BY THE RECESSED AND FULLY GLAZED MAIN ENTRY. THE PROJECT WAS THE FIRST NEW BUILDING IN CANADA TO RECEIVE A LEED GOLD RATING. SOME OF THE ENVIRONMENTAL DESIGN STRATEGIES INCLUDE NATURAL VENTILATION, DAYLIGHTING AND ENERGY CONSERVATION.

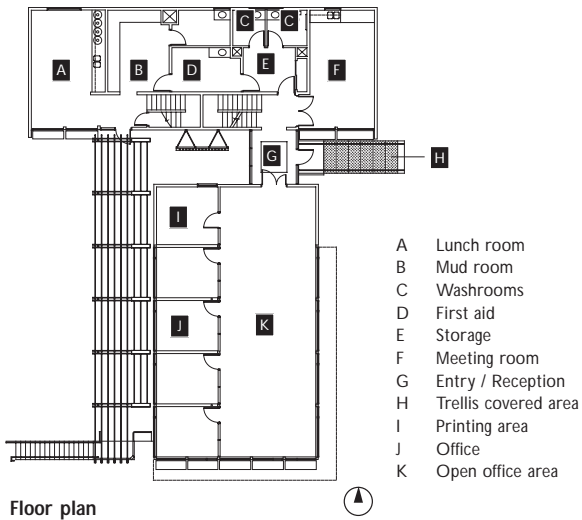

The environmental design strategies included natural ventilation, daylighting and energy conservation, but also encompassed a particularly innovative response to existing site conditions.

The site had previously been used as a sewage treatment plant, and one of the legacies of this former use was a series of circular concrete tanks, two of which proved suitable for use as foundations for the new building. The rectangular structure is supported on beams cantilevering from these tanks, and from certain angles appears to float above the ground.

Each elevation responds to the nature of the environment on that side of the building. To the east, a roof overhang and a row of deciduous trees provide summer shade but allow winter sun penetration. To the south, the roof overhang continues and a projecting horizontal sun shade protects the lower areas of



glazing. To the west, an exterior horizontal trellis and projecting fin walls provide protection from afternoon sun.

By contrast, the north façade is almost entirely solid, its cedar cladding broken only by a few small windows. Cedar was chosen for this, and other service areas of the building as it provided a contrast in colour and texture with the corrugated metal cladding used elsewhere. The cedar was detailed so as to make the wood cladding appear to be panelized, echoing the minimalist look of the glazing units and metal panels.

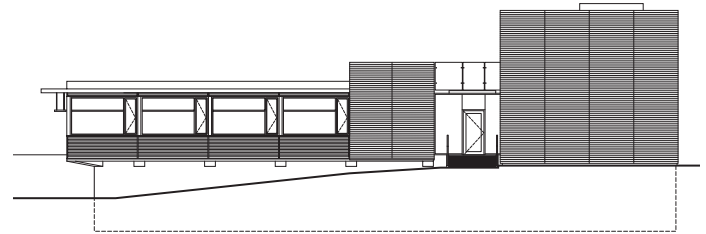
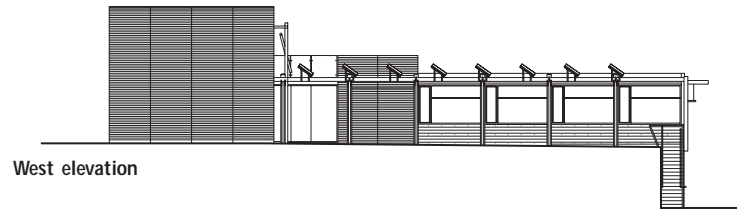

THE NEW BUILDINGS ARE SUPPORTED ON BEAMS CANTILEVERING FROM CIRCULAR CONCRETE TANKS THAT WERE PART OF THE SEWAGE TREATMENT PLANT THAT FORMERLY OCCUPIED THE SITE. TO THE WEST, AN EXTERIOR HORIZONTAL TRELLIS AND PROJECTING FIN WALLS PROVIDE PROTECTION FROM AFTERNOON SUN.



WESTERN RED CEDAR PROVIDES A COLOUR AND TEXTURE CONTRAST WITH THE CORRUGATED METAL CLADDING. THE WESTERN RED CEDAR WAS DETAILED FOR A PANELIZED EFFECT THAT ECHOES THE MINIMALIST LOOK OF THE GLAZING UNITS AND METAL PANELS.



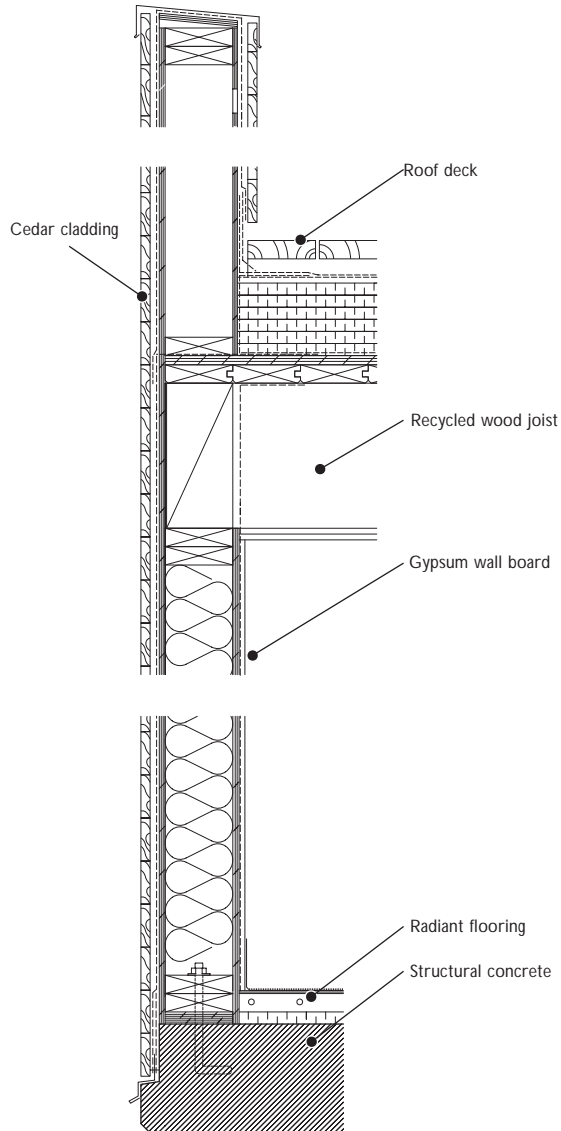

Section, exterior wall



Cedar Specs

The boards are kiln dried / pressure treated S4S Grade B and Better Western Red Cedar, nominal size 1x6, fastened with hot dipped galvanized nails.

Yale Sculpture Building and Gallery

KIERAN TIMBERLAKE ASSOCIATES LLP

The Yale Sculpture Building and Gallery, Newhaven Connecticut, extends the University's extraordinary arts district westward, and establishes altogether new urban relationships with the city at the edge of the campus. Situated on previously developed land, the new complex is arranged so as to invite the city into and through the site while providing perimeter street frontage where none existed before.





THE SCULPTURE GALLERY CREATES AN APPROPRIATELY SCALED STREET FRONTAGE ADJACENT TO THE HISTORIC HOUSES ALONG EDGEWOOD STREET. THE GLASS WALLS ON THE FRONT OF THE GALLERY FOLD AWAY TO BECOME AN OPEN PORCH.

The four-storey glass studio building sits in the core of the perimeter block, with a one-storey storefront gallery on the street frontage to the north. Adjacent to the studio building, on the west side, is a four-story parking garage with retail space on the ground floor. The gallery and parking structure reestablish the perimeter block and the east-west path through the site is planned as an outdoor sculpture garden that connects all the way back to Louis Kahn's Yale University Art Gallery.

The 2,800sf sculpture gallery creates an appropriately scaled street frontage adjacent to the historic houses along Edgewood Street. The glass walls on the front of the gallery fold away to become an open porch. An interior underground ramp connects the gallery back to the entry lobby of the studio building. A sculptural steel stair zigzags from the basement to the fourth floor of the studio building, while landscaped terraces on the second and third floors provide views to the gallery's green roof and the city of Newhaven beyond.



Site plan

Gallery





Cedar Specs

Reclaimed 2-1/8 in. x 7/8-in. unfinished Western Red Cedar planks designed as a rainscreen system with open joints.

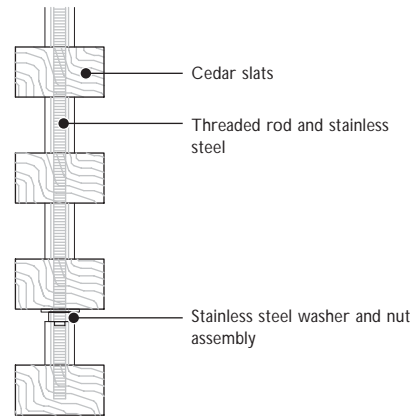

Detail at bottom of edge

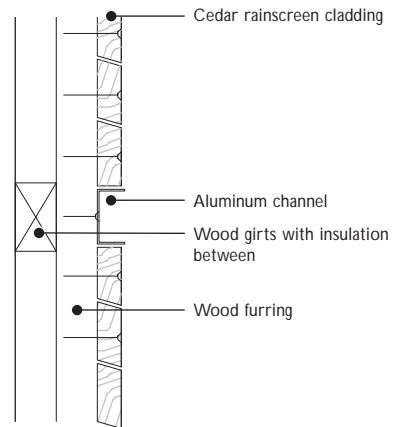

Section, detail at wood rainscreen



THE EXTERIOR WALL OF THE GALLERY BUILDING IS DESIGNED AS A PRESSURE EQUALIZED RAIN SCREEN WALL CLAD WITH 2-1/8 IN. X 7/8-IN. RECLAIMED WESTERN RED CEDAR. THE SLOTTED WESTERN RED CEDAR SCREEN PROVIDES A STIMULATING ELEMENT OF TRANSPARENCY AND SHADING AT THE STREET ENTRANCE.

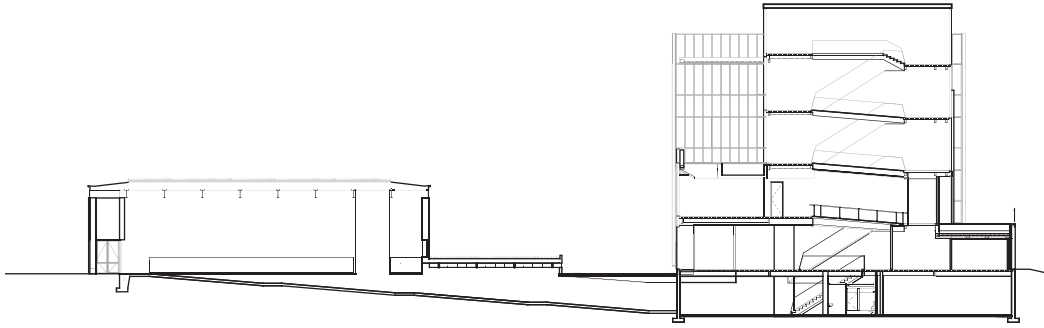

Section through gallery and studio building



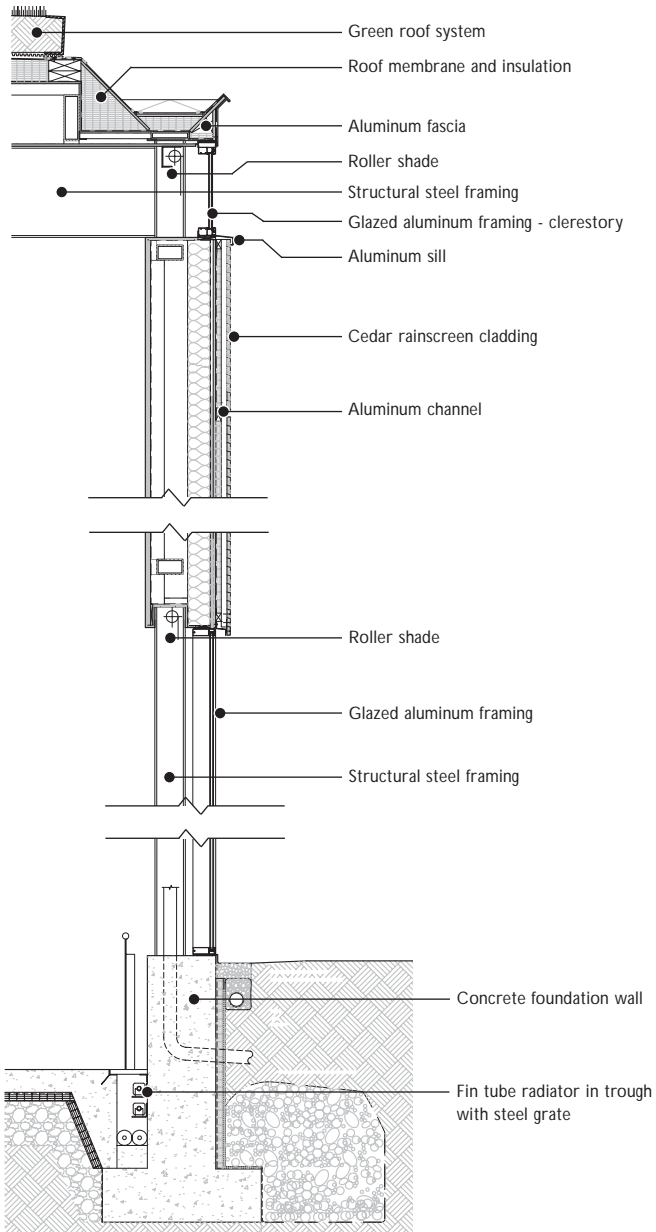

Section, gallery west wall

LEFT TO WEATHER NATURALLY TO MINIMIZE MAINTENANCE, THE WESTERN RED CEDAR CLADDING HELPS THE GALLERY CONFORM TO THE CHARACTER AND SCALE OF THE NEIGHBOURING HISTORIC DISTRICT.

The exterior wall of the gallery building is designed as a pressure equalized rain screen wall, and is made up of 2-1/8 in. by 7/8-in. reclaimed Western Red Cedar planks. The use of wood cladding for the gallery building is in keeping with the character and scale of the wood framed houses in the neighbouring historic district. The cedar was left unpainted, with the expectation that it would weather naturally to a silver/grey colour. An additional benefit of leaving the wood unfinished is that it will not require repainting by the university maintenance staff.





OWNER Yale University
ARCHITECT Kieran Timberlake Associates LLP
STRUCTURAL ENGINEER CVM Engineers
MECHANICAL/ELECTRICAL ENGINEER BVH Integrated Services
CONSTRUCTION MANAGER Shawmut Design and Construction
ENVIRONMENTAL CONSULTANT Atelier Ten/Triton Environmental Inc.
LANDSCAPE ARCHITECT Andropogon Associates
WESTERN RED CEDAR SUPPLIER Armster Reclaimed Lumber Company
PHOTOS Peter Aaron/Esto

