

# REAL CEDAR DARTBOARD CABINET

**DESIGN:** REAL CEDAR ORIGINAL

This dartboard cupboard is the perfect recreational accessory for game rooms, man caves and cottages. The entire design calls for beautiful Western Red Cedar, so it's ideal for mounting outside! Real Cedar is naturally resistant to rot, decay and insects, which means it can stand up to the elements and protect your game year round. It's also a pleasure to work with. It's a durable, yet surprisingly lightweight, building material that lays straight and holds fasteners like a dream.

When it comes to specifying sizes, we recommend asking your local Real Cedar retailer if they have any short lengths in stock. Using short lengths means less cutting, less waste and more savings for you. Search for kiln dried material, if available.

Go to [realcedar.com](http://realcedar.com) to see accompanying video.

## WHAT YOU'LL NEED

Part #	Description	FINISHED SIZE			Nominal sizes	Material	Qty.
		T	W	L			
<b>Box</b>							
A1	Back	3/4"	5 1/2"	43 1/2"	1x6	WRC Select Knotty	2
A2	Back	3/4"	5 1/2"	38"	1x6	WRC Select Knotty	2
B	Back brace	3/4"	3 1/2"	22"	1x4	WRC Select Knotty	3
C	Sides	3/4"	5 1/2"	35 1/4"	1x6	WRC Select Knotty	2
D1	Shelf	3/4"	5 1/2"	22"	1x6	WRC Select Knotty	1
D2	Shelf	3/4"	3 1/2"	22"	1x4	WRC Select Knotty	1
E1	Roof	1 1/2"	7 1/2"	22 1/2"	2x8	WRC Select Knotty	1
E2	Roof	1 1/2"	7 1/2"	21"	2x8	WRC Select Knotty	1
F1	Roof support	3/4"	3/4"	13 1/4"	1x1	WRC Select Knotty	1
F2	Roof support	3/4"	3/4"	12 1/2"	1x12	WRC Select Knotty	1
G	Brace	3/4"	3 1/2"	22"	1x4	WRC Select Knotty	1

<b>Door</b>							
H1	Door	3/4"	5 1/2"	46 1/4"	1x6	WRC Select Knotty	2
H2	Door	3/4"	5 1/2"	40 3/4"	1x6	WRC Select Knotty	2
H3	Door brace	3/4"	1 1/2"	10"	1x2	WRC Select Knotty	6

<b>Hardware</b>							
I	1 1/4" Hot dipped galvanized finishing nails or stainless steel brad nail						20
J	1 1/4" Stainless steel screws*						80
K	3" Stainless steel screws*						3
L	24" Continuous hinge						2
M	Barrel bolt door latch						1

\* Galvanized nails can be used as an alternative to the Stainless Steel screws.

\*\*Actual finished sizes may vary. Check with your Real Cedar retailer.

## INSTALLATION PRO TIPS

1. Where gluing is required, only apply a polyurethane construction adhesive specially formulated for outdoor applications. Using a scrap of wood, spread a thin even layer of glue, like butter on toast. Avoid applying excessive amounts and keep glue at least 1/2" away from exterior edges of joint to avoid unappealing bleed out. Press pieces in place briefly, then pull them apart for a second before pressing firmly back in place (this helps activate the glue so it will set faster). Always use clamps to keep pieces in position while driving in screws because until the glue dries, pieces are at risk of slipping.
2. For all outdoor work, you should use corrosion-resistant stainless steel or hot-dipped galvanized nails. Other fasteners and hardware such as bolts, screws and hinges should also be made from similar corrosion resistant materials.
3. You can let the cedar weather naturally (eventually turning a beautiful silvery patina), or you can choose to finish the structure - in which case, apply the finish to all six sides of the components before assembly. For all outdoor work, you should use corrosion-resistant stainless steel or hot dipped galvanized nails to avoid black weeping lines. Other fasteners and hardware such as bolts, screws and hinges should also be made from similar corrosion resistant materials.

**NOTE:** Real Cedar is not responsible for any personal injury or property damage sustained in connection to these guidelines.

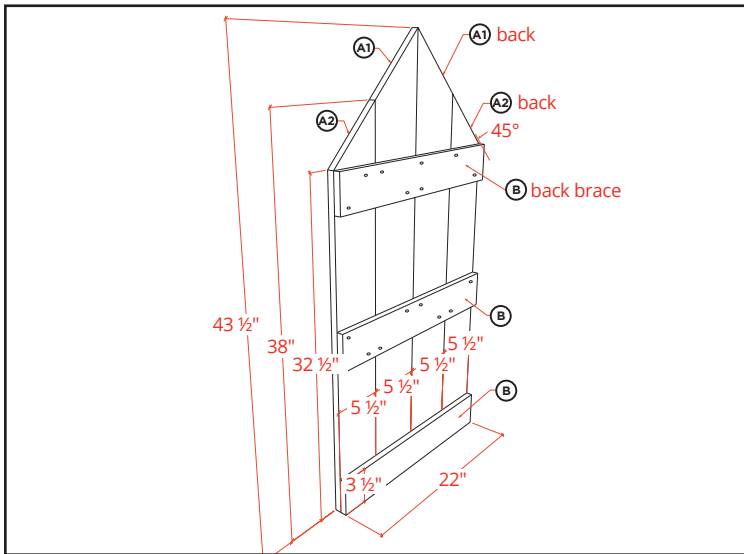

### STEP 1 - Build Back Board

Cut all back pieces according to lengths and angles illustrated in diagram. Then, working on a flat surface, line up two (A1) backs with an (A2) back on either side. Connect with three (B) braces.

Use #8 1 1/4" Stainless wood screws per brace.

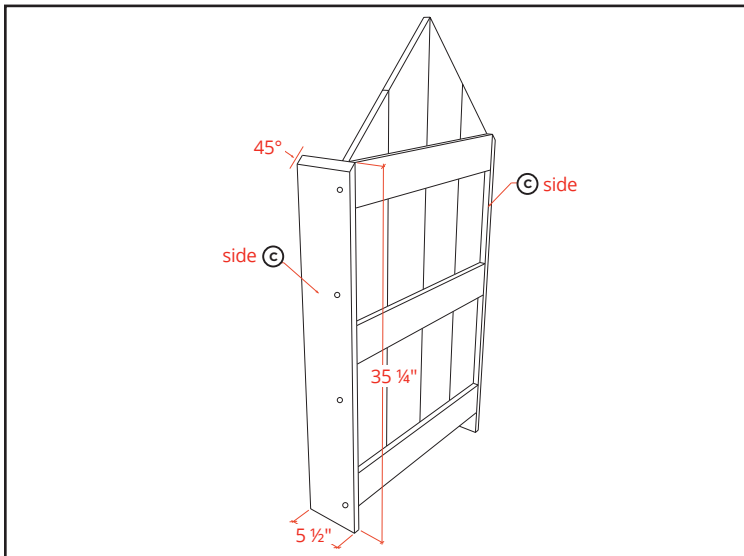

### STEP 2 - Attach sides

Keeping in mind the (B) braces will be the back side of the cupboard, attach one (C) frame on either side of the back.

Use #8 1 1/4" Stainless wood screws.

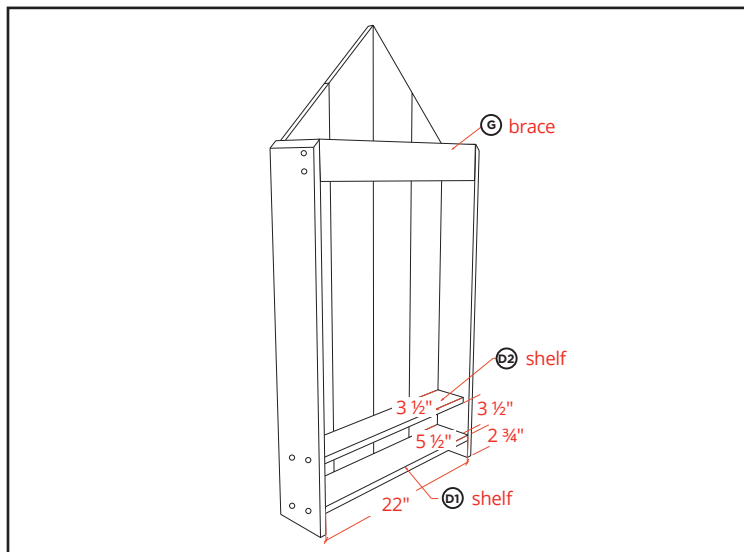

### STEP 3 - Install shelves

Fasten (D2) shelf and (D1) and (G) brace shelf between the (C) frames. Note: Brace slides below the back board.

Use #8 1 1/4" Stainless wood screws.

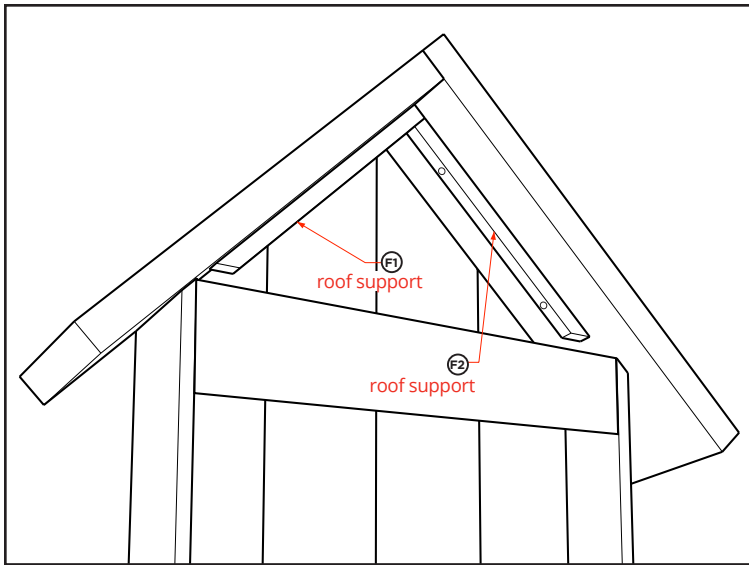

#### STEP 4 - Insert Roof Supports

Attach (F1) roof support to (E2) roof and then fasten (F2) support to (E1) roof. Inset 2" from the edge of the roof, connect roof pieces with #8 3" Stainless wood screws.

Attach supports with #8 1 1/4" Stainless wood screws. Pre-drill holes to avoid splitting.

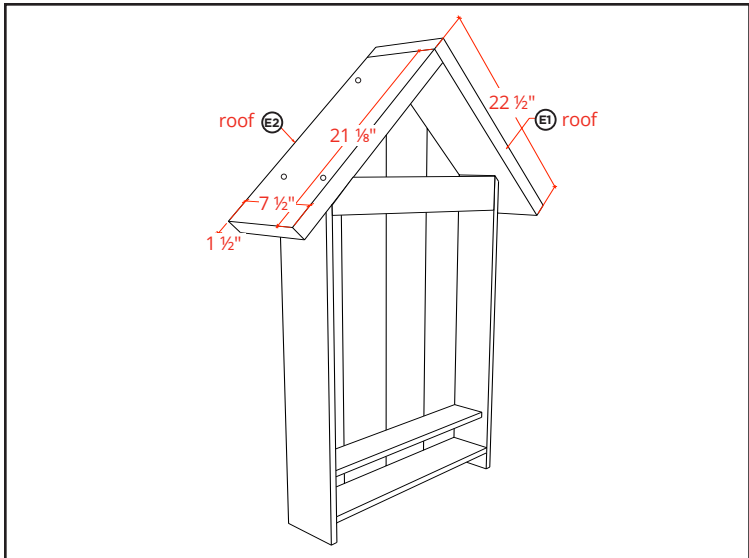

#### STEP 5 - Add Roof

Working on a flat surface connect (E1) roof to (E2) roof and then attach to top of back board and (C) sides.

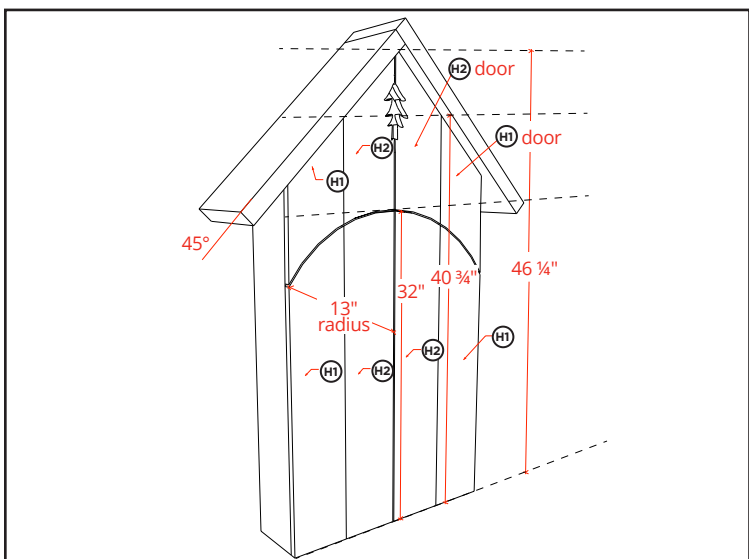

#### STEP 6 - Layout Front and Build Doors

For each door, line up one (H2) piece with one (H1). Cut doors at 32" across. This cut can be made straight across or can be cut in an arc with a jigsaw (13" radius). Decorative tree is cut using a jigsaw.

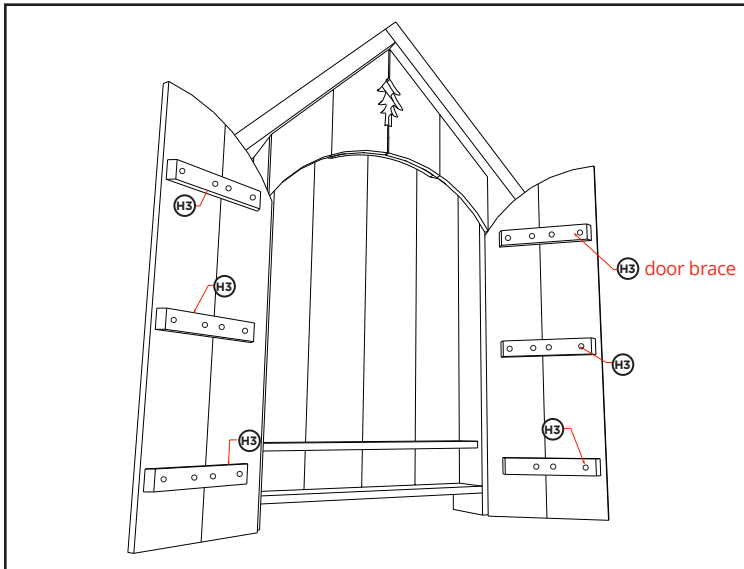

## STEP 7 - Build and Install Doors

Fasten doors together with three (H3) pieces on either side (use #8 1 1/4 Stainless wood screws). Install each door with one (K) hinge (24") and add 3" barrel bolt door latch.

Note: Drill the top of (H3) piece to provide a great place for your darts.

